

금융 2001-01

KAMCO의 국민경제적 역할과 중장기 발전 전략

2001. 3. 14

강 동 수

한 국 개 발 연 구 원



KAMCO

2001. 3. 14.



1. KAMCO

2.

3. KAMCO

4.

5.

6.

7.

8.

1. KAMCO

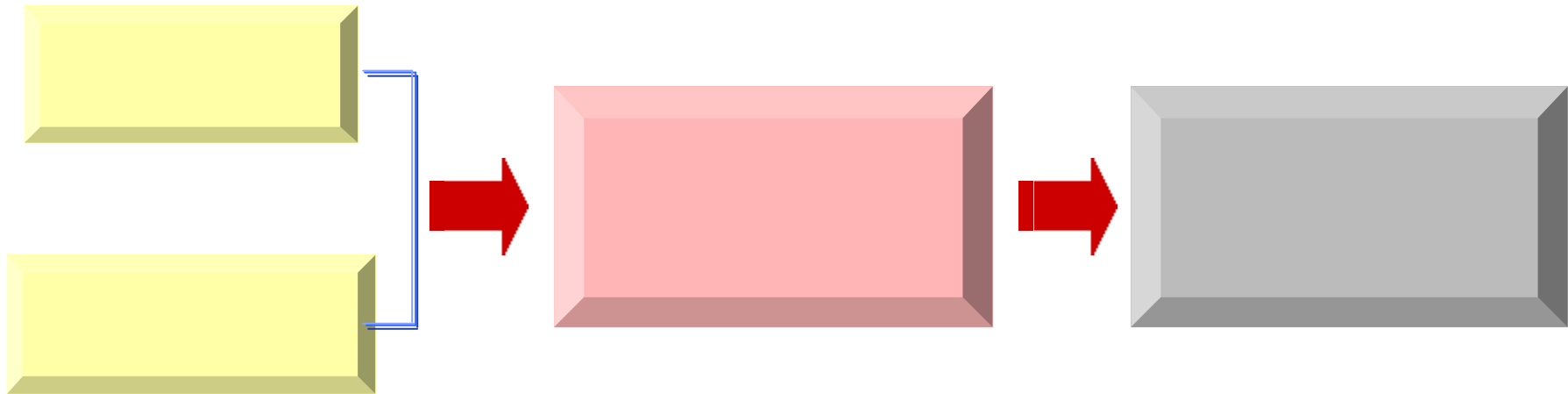

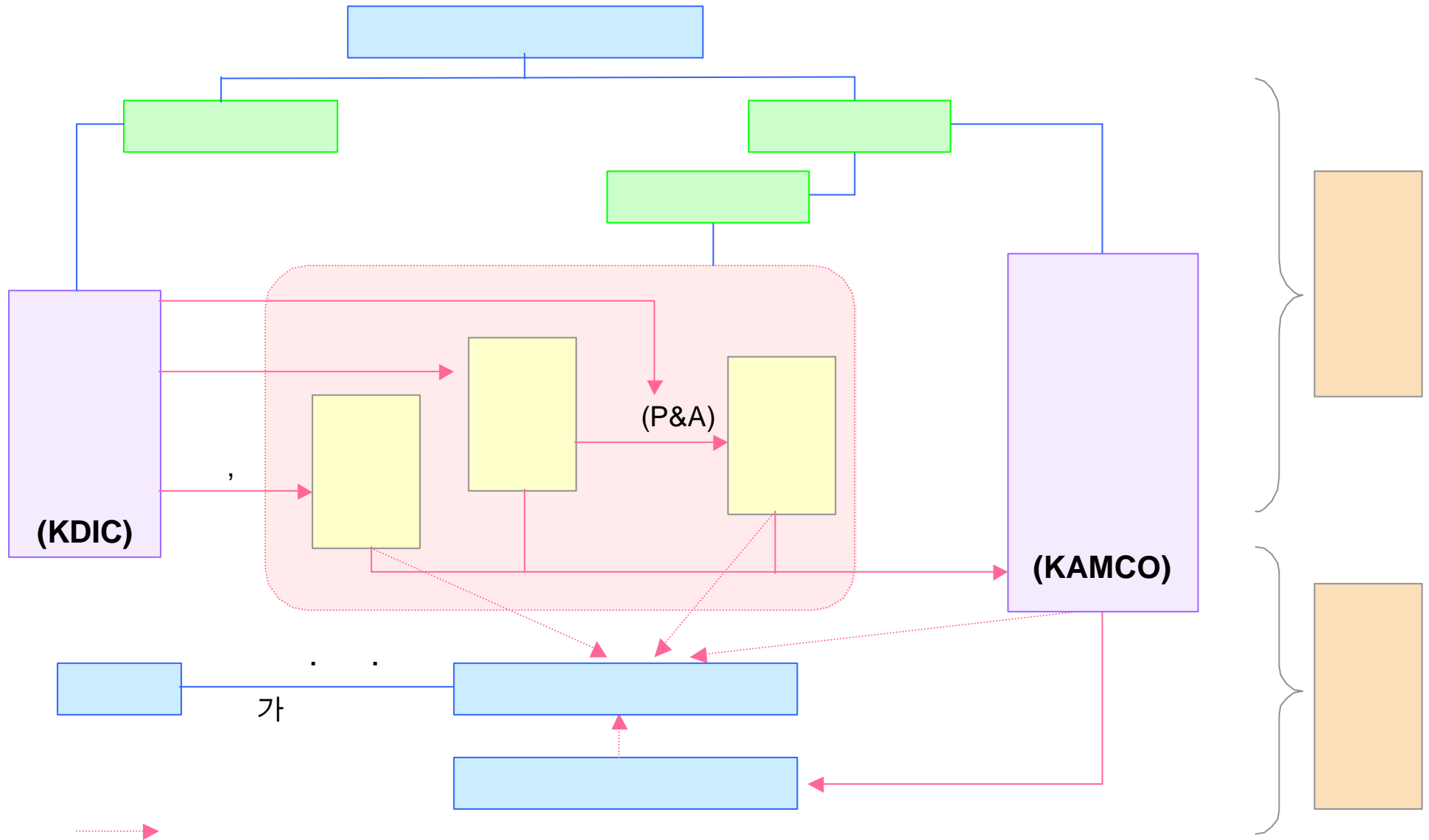

3. KAMCO

•	가	85.3					
(가	34.9		40.9%			
•	가	46.9					
(19.2		21.7	2.5	*)
							*

•							.
{	2000	11	NPL(Non-Performing Loan) Forum				
	2000	12	FIDF				
	2001	4			MOU		
	2001		4				

3. KAMCO

-

(:)

		1998		1999		2000 12			
		90,887	58,567	25,761	14,135	675	550	117,323	73,352
		100,508	15,759	34,161	1,474	15,331	3,105	150,000	20,338
		191,395	74,426	59,922	15,609	16,006	3,655	267,323	93,690
		166,635	91,740	19,346	7,903	1,358	750	187,339	100,393
		82,725	32,907	40,088	5,179	4,138	510	126,951	38,596
		249,360	124,547	59,434	13,082	5,496	1,260	314,290	138,989
						271,327	115,926	271,327	115,926
		440,755	198,973	119,356	28,691	292,829	120,841	852,940	348,605

3. KAMCO

-

(:)

				가					
	60,272	13,031	15,975				60,272	13,031	15,975
ABS	72,882	38,571	37,801				72,882	38,571	37,801
.	78,885	23,719	28,610				78,885	23,719	28,610
AMC	17,099	4,486	6,780				17,099	4,486	6,780
CRC	8,527	1,397	2,665	9,466	2,661	4,759	17,993	4,058	7,424
	3,186	1,008	1,293	3,077	1,021	1,378	6,263	2,029	2,671
	65,575	25,429	36,450				65,575	25,429	36,450
	306,426	107,641	129,574	12,543	3,682	6,137	318,969	111,323	135,711
.	149,858	80,912	80,912				149,858	80,912	80,912
	456,284	188,553	210,486	12,543	3,682	6,137	468,827	192,235	216,623

4. KAMCO

•

-
-

• 가
• KAMCO가 market maker 가가

, , ,

-
- 가가 .

[Redacted]

- (Time Inconsistency)*
- * 가
-

[Redacted]

-
-

[Redacted]

-
-
-

[Redacted]

- KAMCO 「 」
-

[Redacted]

- 「 」
-

[Redacted]

-
-
-

「

」

- KAMCO

가

-

「

」 가 가

-

-

[Redacted]

-
-
-

[Redacted]

-
- downsizing

[Redacted]

-
-
-

[Redacted]

- DB
-

7.

(II): ()

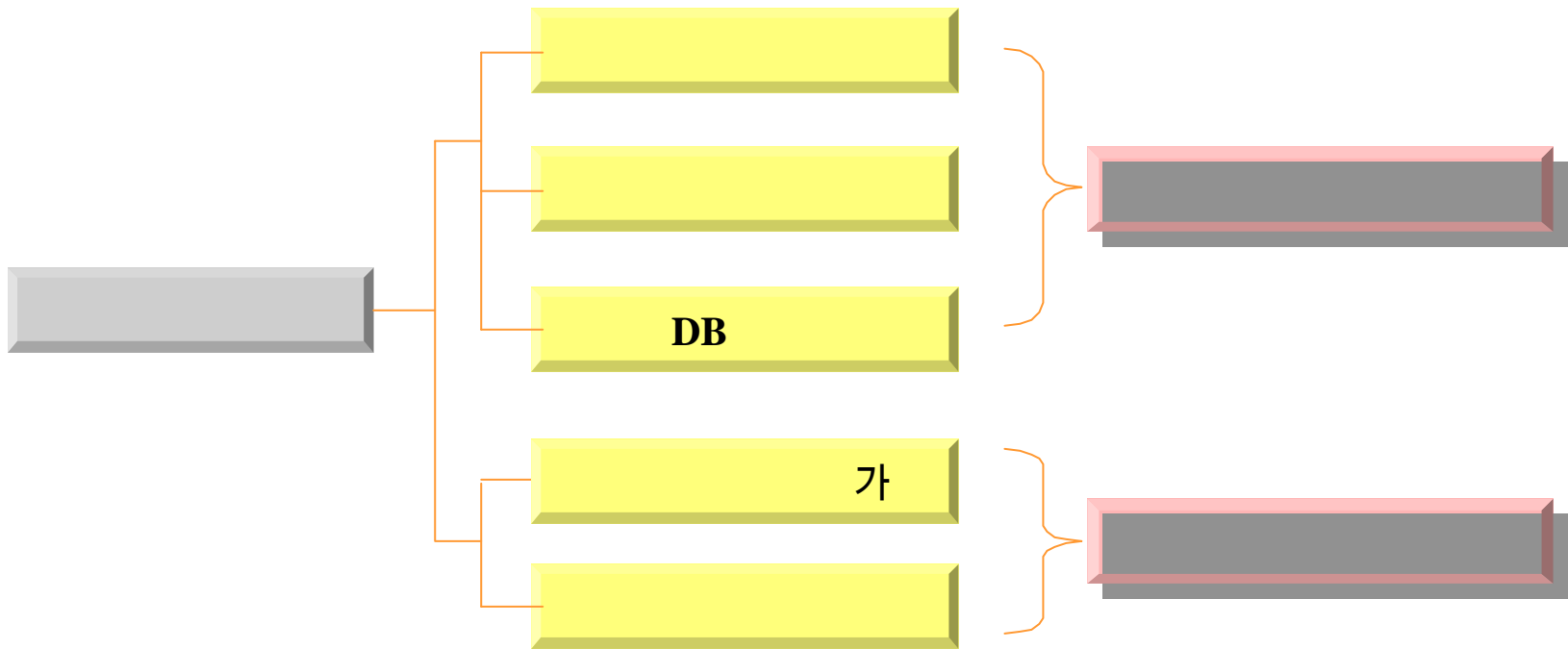
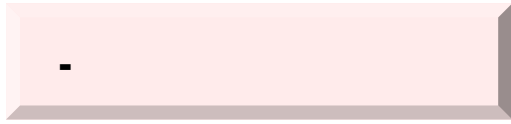

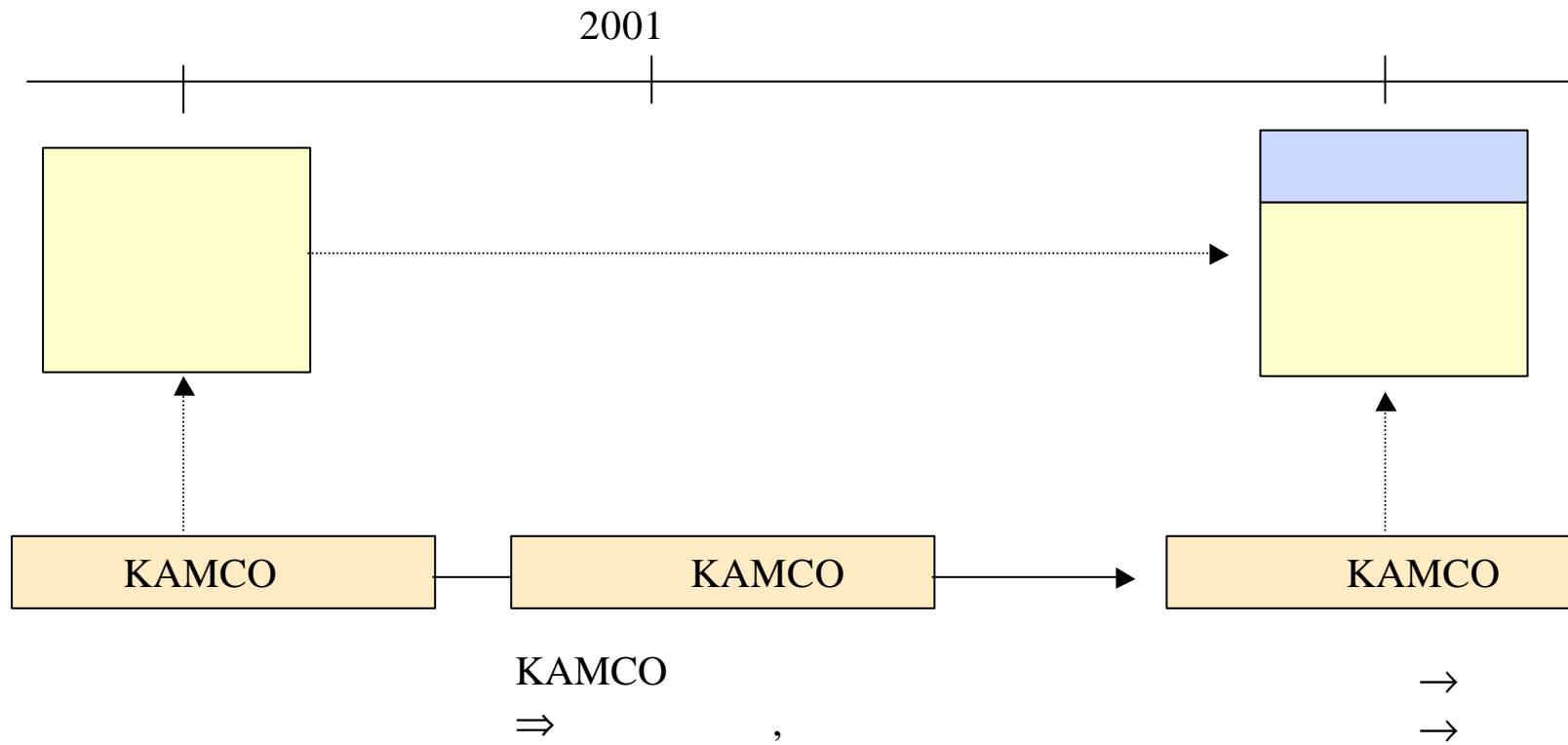
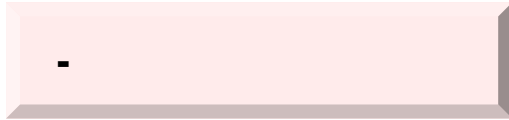

KAMCO

- 80%
- 가

(Pooling) 가가

- (NYU Altman) 46% 가 가
- 가 2/3 가

가가

가	1000	1000
	20 ×50	1000 ×1
가	40%	40% ×(1+0.46)=58.4%
가	20 ×0.4×50=400	1000 ×0.584 ×1=584

(CRV)

- () CRV
- 가가 CRV AMC

KAMCO

- KAMCO (가 40%)
- KAMCO가 2/3 가 가가 가 가
- 가가

KAMCO

- 2000 5,583 (2001 6 가 2)
가 38.4 (가 13.2)
15.7

(:)

	1998	1999	2000	2001	2002	2003	2004	
		6,287	41,453	4,067	9,679	121,925	21,589	205,000
	2,663	13,549	16,181	12,174	11,857	12,423	4,429	73,276
	5,068	83	1,276	-	-	-	-	6,427

KAMCO

- 3 5
- KAMCO가 2003 가

⇒

[Redacted]

- ,
- 가

[Redacted]

- KAMCO
- 2 3
- ,

KAMCO

-
-

KAMCO

가가

-
-

()

- KAMCO
-

가가

가