

Financial Intermediation and the Post-Crisis Financial System with Implications for Korea*

Hyun Song Shin
Princeton University
hsshin@princeton.edu

August 2009

Abstract

Securitization was meant to disperse credit risk to those who were better able to bear it. In practice, securitization appears to have concentrated the risks in the financial intermediary sector itself. This paper outlines an accounting framework for the financial system for assessing the impact of securitization on financial stability. If securitization leads to the lengthening of intermediation chains, then risks becomes concentrated in the intermediary sector with damaging consequences for financial stability. Covered bonds are one form of securitization that do not fall foul of this principle. I discuss the role of countercyclical capital requirements and the Spanish-style statistical provisioning in mitigating the harmful effects of lengthening intermediation chains. For Korea, the stability of funding emerges as a key consideration. Covered bonds may play a role in stabilizing the funding arrangement for banks.

*Paper for the 2009 KDI JEP conference. This paper draws on the paper for the 8th BIS Annual Conference, June 25-26, 2009. I am grateful to Tobias Adrian, Markus Brunnermeier and Stephen Morris for discussions during the preparation of this paper.

1. Introduction

The current financial crisis has the distinction of being the first post-securitization crisis in which banking and capital market developments have been closely intertwined. Historically, banks have always reacted to changes in the external environment, expanding and contracting lending in reaction to shifts in economic conditions. However, in a market-based financial system built on securitization, banking and capital market developments are inseparable, and the current crisis is a live illustration of the potency of the interaction between the two.

Securitization was meant to disperse credit risk to those who were better able to bear it, but in the financial crisis the risks appear to have been concentrated in the financial intermediary sector itself, rather than with the final investors. To understand the true role played by securitization in the financial crisis, we need to dispose of two pieces of received wisdom concerning securitization - one old and one new. The old view, now discredited, emphasized the positive role played by securitization in dispersing credit risk, thereby enhancing the resilience of the financial system to defaults by borrowers.

But having disposed of this old conventional wisdom, the fashion now is to replace it with a new one that emphasizes the chain of unscrupulous operators who passed on bad loans to the greater fool next in the chain. We could dub this new fashionable view the “hot potato” hypothesis, since the bad loan is like a hot potato passed down the chain. The idea is attractively simple, and there is a convenient villain to blame, and so has figured in countless speeches given by central bankers and politicians on the causes of the subprime crisis.

But the new conventional wisdom is just as flawed as the old one. Not only does it fall foul of the fact that securitization worked well for thirty years before the subprime crisis, it fails to distinguish between *selling* a bad loan down the

	Total reported sub-prime exposure (US\$bn)	Percent of reported exposure
Investment Banks	75	5%
Commercial Banks	418	31%
GSEs	112	8%
Hedge Funds	291	21%
Insurance Companies	319	23%
Finance Companies	95	7%
Mutual and Pension Funds	57	4%
Leveraged Sector	896	66%
Unleveraged Sector	472	34%
Total	1,368	100%

Figure 1.1: Subprime exposures by type of institution (source: Greenlaw, Hatzius, Kashyap and Shin (2008))

chain and *issuing liabilities* backed by bad loans. By selling a bad loan, you get rid of the bad loan and it's someone else's problem. In this sense, the hot potato is passed down the chain to the greater fool next in the chain. However, the second action has a different consequence. By issuing liabilities against bad loans, you do not get rid of the bad loan. The hot potato is sitting on your balance sheet or on the books of the special purpose vehicles that you are sponsoring. Thus, far from passing the hot potato down the chain to the greater fool next in the chain, you end up keeping the hot potato. In effect, the large financial intermediaries are the last in the chain. While the investors who buy your securities will end up losing money, the financial intermediaries that have issued the securities are in danger of larger losses. Since the intermediaries are leveraged, they are in danger of having their equity wiped out, as some have found to their cost.

Indeed, Greenlaw, Hatzius, Kashyap and Shin (2008) report that of the approximately 1.4 trillion dollar total exposure to subprime mortgages, around half

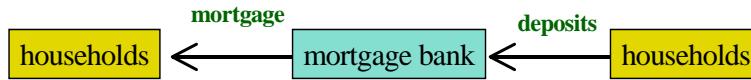

Figure 1.2: Short Intermediation Chain

of the potential losses were borne by US leveraged financial institutions, such as commercial banks, securities firms and hedge funds. When foreign leveraged institutions are included, the total exposure of leveraged financial institutions rises to two thirds (see Figure 1.1). Far from passing on the bad loans to the greater fool next in the chain, the most sophisticated financial institutions amassed the largest exposures to the bad assets.

A characteristic feature of financial intermediation based on the US-style securitization system is the long chains financial intermediaries involved in channeling funds from the ultimate creditors to the ultimate borrowers. The difference can be illustrated in figures 1.2 and 1.3. Figure 1.2, depicts a traditional deposit-taking bank that collects deposits and holds mortgage assets against household borrowers. Until around 1990, the bulk of home mortgage assets in the United States were held by savings institutions and commercial banks (see Adrian and Shin (2008)).

In recent years, however, the proportion of home mortgages held in government sponsored enterprise (GSE) mortgage pools have become the dominant holders. The chain of financial intermediation has become correspondingly much longer and more heavily dependent on overall capital market conditions. Figure 1.3 illustrates one possible chain of lending relationships whereby credit flows from the ultimate creditors (household savers) to the ultimate debtors (households who obtain a mortgage to buy a house). In this illustration, the mortgage asset is held in a mortgage pool - a passive firm whose sole role is to hold mortgage

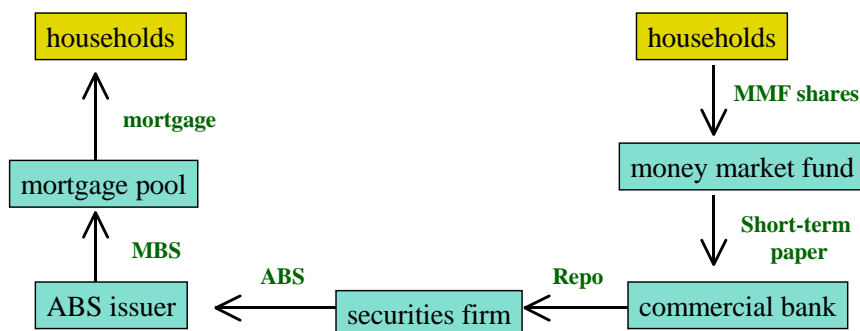

Figure 1.3: Long Intermediation Chain

assets and issue liabilities (mortgage-backed securities, MBSs) against those assets. The mortgage-backed securities might then be owned by an asset-backed security (ABS) issuer who pools and tranches the MBSs into another layer of claims, such as collateralized debt obligations (CDOs). Then, a securities firm (a Wall Street investment bank, say) might hold CDOs on their own books for their yield, but finances such assets by collateralized borrowing through repurchase agreements (repos) with a larger commercial bank. In turn, the commercial bank would fund its lending to the securities firm by issuing short term liabilities, such as financial commercial paper. Money market mutual funds would be natural buyers of such short-term paper, and ultimately the money market fund would complete the circle, since household savers would own shares to these funds.

Of course, the illustration in Figure 1.3 is a simple example of potentially much more complex and intertwined relationships. For instance, the same security could be used several times in repo lending as the lender turns round and pledges the same security as collateral to another lender (the practice known as “re-hypothecation”). In that case, the chain would be much longer and more involved. Nor does the illustration take account of off-balance sheet vehicles such as structured investment vehicles (SIVs) or ABCP conduits that the commer-

cial bank might set up in order to finance the direct holding of CDOs and other asset-backed securities.

What is noticeable from the institutions involved in Figure 1.3 is that they were precisely those institutions that were at the sharp end of the financial crisis of 2007 and 2008. Subprime mortgages cropped up in this chain, and the failure of Bear Stearns and Lehman Brothers owed to problems in the smooth function of this chain. This realization begs the question of what advantages can be gained by such long intermediation chains.

One possible argument might be that securitization enables the dispersal of credit risk to those who can best bear losses. We have already commented on the apparent failure of this particular mechanism, but we will return to examine it more closely below. Leaving that to one side, another possible justification for long intermediation chains is that there is an inherent need for maturity transformation in the financial system because ultimate creditors demand short-term claims, and that the process of stringing together long lending relationships make it easier to perform the overall maturity transformation role.

There are well known arguments for the desirability of short-term debt for incentive reasons - in particular in disciplining managers. Calomiris and Kahn (1991) have argued that demand deposits for banking arose naturally as a response by the bank's owners and managers to commit not to engage in actions that dissipate the value of the assets, under pain of triggering a depositor run. Diamond and Rajan (2001) have developed this argument further, and have argued that the coordination problem inherent in a depositor run serves as a commitment device on the part of the depositors not to renegotiate in the face of opportunistic actions by the managers. When the bank has the right quantity of deposits outstanding, any attempt by the banker to extort a rent from depositors will be met by a run, which drives the banker's rents to zero. Foreseeing this, the banker

will not attempt to extort rents. In a world of certainty, the bank maximizes the amount of credit it can offer by financing with a rigid and fragile deposit-only capital structure.

However, in both Calomiris and Kahn (1991) and Diamond and Rajan (2001), the focus is on traditional bank deposits, where the creditors are not financial intermediaries themselves. However, what is notable about the financial boom and bust cycle witnessed recently is that the largest fluctuations in ultra short-term debt has not been associated with the liabilities to retail depositors, but rather with the liabilities to other financial intermediaries. Adrian and Shin (2009) compare the stock of repurchase agreements of US primary dealers plus the stock of financial commercial paper expressed as a proportion of the M2 stock. M2 includes the bulk of retail deposits and holdings in money market mutual funds, and so is a good proxy for the total stock of liquid claims held by ultimate creditors against the financial intermediary sector as a whole. As recently as the early 1990s, repos and financial CP were only a quarter of the size of M2. However, the total rose rapidly reaching over 80% of M2 by the eve of the financial crisis in August 2007, only to collapse with the onset of the crisis.

The ultra-short nature of the financial intermediary obligations to each other can be better seen when plotting the overnight repos component of the overall repo series. Figure 1.4 plots the size of the overnight repo stock, financial commercial paper and M2, normalized to be equal to 1 on July 6th, 1994 (the data on overnight repos are not available before that date). The stock of M2 has grown by a factor of around 2.4 since 1994, but the stock of overnight repos grew almost seven-fold up to March 2008. Brunnermeier (2009) has noted that the use of overnight repos became so prevalent that, at its peak, the Wall Street investment banks were rolling over a quarter of their balance sheets every night. What is evident from Figure 1.4 is that the rapid growth and subsequent collapse of the overnight

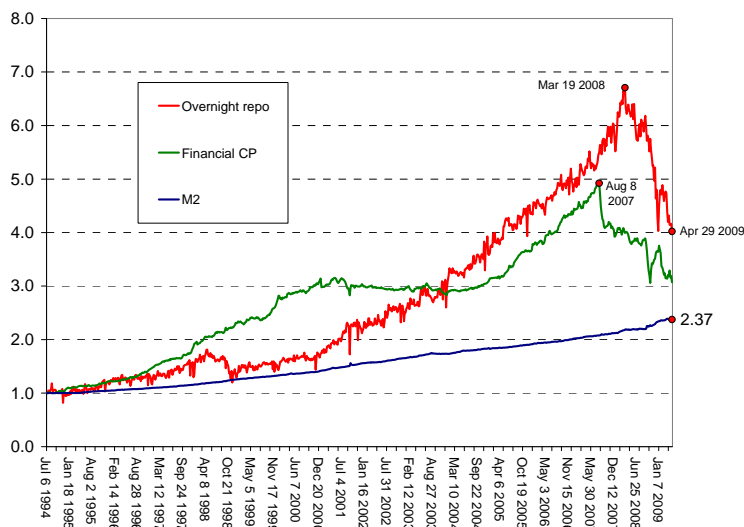

Figure 1.4: Overnight repos, financial commercial paper and M2 (normalized to 1 on 6 July 1994)

repos cannot be easily explained by the demand for short-term liquid claims of retail depositors.

2. An Accounting Framework

Consider a stylized financial system for the allocation of credit in the economy depicted in Figure 2.1. The financial system channels savings from the lenders to ultimate borrowers. The ultimate lenders are households, either directly or indirectly through institutions such as pension funds, mutual funds and life insurance companies.

Some credit will be directly provided from the lender to the borrower. Treasury bonds or municipal bonds are a good example of such direct credit where the lender holds a direct claim on the borrower. However, the sizeable borrowing

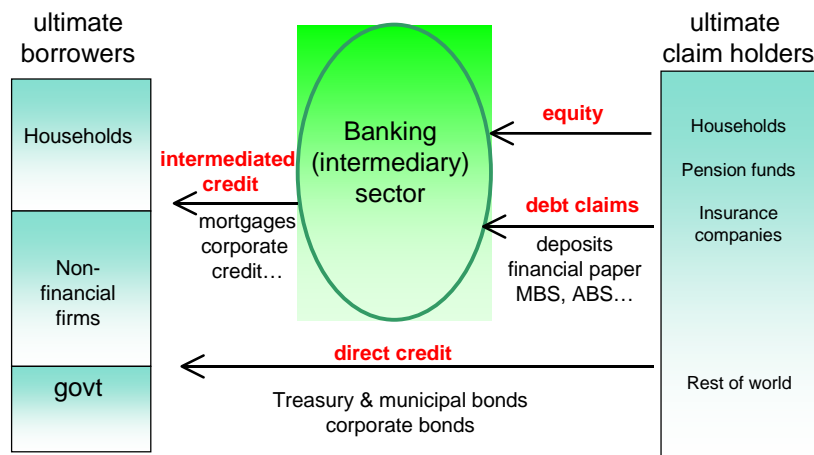

Figure 2.1: Stylized Financial System for Credit

of the household sector - either mortgages or consumer debt - is almost always intermediated through the banking system, broadly defined. At the end of 2008, US household sector mortgage liabilities amounted to around \$10.6 trillion, and consumer debt accounts for another \$2.5 trillion.

The accounting framework presented here is based on the picture of credit flow given in Figure 2.1, and is drawn from Shin (2009). There are n financial intermediaries standing between the ultimate borrowers and the ultimate creditors. For convenience, we denote these intermediaries simply as “banks”.

Denote by y_i the claim held by bank i on the ultimate borrowers, such as household mortgages or consumer loans. For our purposes in this paper, it does not matter much whether y_i is in face values or market values, since the purpose of this paper is to outline the underlying accounting relationships within the financial system. However, in what follows, it is useful to interpret all quantities as being in market values, since the comparative statics take on additional richness due to

valuation effects.¹

As well as claims on the ultimate borrowers, the banks hold claims against each other. Denote by x_i the total value of the liabilities of bank i , by x_{ij} the value of bank i 's liabilities held by bank j and by π_{ij} the share of bank i 's liabilities that are held by bank j . Denoting by e_i the value of equity of bank i , the balance sheet of bank i is

Assets	Liabilities
y_i	e_i
$\sum_{j=1}^n x_j \pi_{ji}$	x_i

(2.1)

The balance sheet identity of bank i is:

$$y_i + \sum_j x_j \pi_{ji} = e_i + x_i \tag{2.2}$$

The left hand side is the value of assets and the right hand side is the sum of debt (x_i) and equity (e_i). The matrix of claims and obligations between banks can then be depicted as below. The (i, j) th entry in the table is the debt owed by bank i to bank j . Then, the i th row of the matrix can be summed to give the total value of debt of bank i , while the i th column of the matrix can be summed to give the total assets of bank i . We can give the index $i + 1$ to the outside creditor sector (households, pension funds, mutual funds etc.), so that $x_{i,n+1}$ denotes bank i 's liabilities to the outside claimholders. Deposits would be the prime example of a liability that a bank has directly to outside creditors.

¹See Shin (2009) for more details on the relationship between book values and market values in an interconnected balance sheet network.

	bank 1	bank 2	⋯	bank n	outside	debt
bank 1	0	x_{12}	⋯	x_{1n}	$x_{1,n+1}$	x_1
bank 2	x_{21}	0	⋯	x_{2n}	$x_{2,n+1}$	x_2
⋮	⋮	⋮	⋮	⋮	⋮	
bank n	x_{n1}	x_{n2}	⋯	0	$x_{n,n+1}$	x_n
end-user loans	y_1	y_2	⋯	y_n		
total assets	a_1	a_2	⋯	a_n		

From the balance sheet identity (2.2), we can express the vector of debt values across the banks as follows, where Π is the $n \times n$ matrix where the (i, j) th entry is π_{ij} .

$$[x_1, \dots, x_n] = [x_1, \dots, x_n] \begin{bmatrix} \Pi \end{bmatrix} + [y_1, \dots, y_n] - [e_1, \dots, e_n] \quad (2.3)$$

or more succinctly as

$$x = x\Pi + y - e \quad (2.4)$$

Solving for y ,

$$y = e + x(I - \Pi)$$

Define the leverage of bank i as the ratio of the total value of assets to the value of its equity. Denote leverage by λ_i . That is,

$$\lambda_i \equiv \frac{a_i}{e_i} \quad (2.5)$$

Since $x_i/e_i = \lambda_i - 1$, we have $x = e(\Lambda - I)$, where Λ is the diagonal matrix whose i th diagonal entry is λ_i . Thus

$$y = e + e(\Lambda - I)(I - \Pi) \quad (2.6)$$

Thus, the profile of total lending by the n banks to the end-user borrowers depends on the interaction of three features of the financial system - the distribution of equity e in the banking system, the profile of leverage Λ and the structure of the financial system given by Π . Total lending to end users is increasing in equity and in leverage, as one would expect. More subtle is the role of the financial system, as given by the matrix Π . Define the vector z as

$$z \equiv (I - \Pi) u \tag{2.7}$$

where

$$u \equiv \begin{bmatrix} 1 \\ \vdots \\ 1 \end{bmatrix}$$

so that $z_i = 1 - \sum_{j=1}^n \pi_{ij}$. In other words, z_i is the proportion of bank i 's debt held by the outside claimholders - the sector $n + 1$. Then, total lending to end-user borrowers $\sum_i y_i$ can be obtained by post-multiplying equation (2.6) by u so that

$$\sum_{i=1}^n y_i = \sum_{i=1}^n e_i z_i (\lambda_i - 1) + \sum_{i=1}^n e_i \tag{2.8}$$

Equation (2.8) is the key balance sheet identity for the financial sector as a whole, where all the claims and obligations between banks have been netted out. The left hand side is the total lending to the end-user borrowers. The second term on the right hand side of (2.8) is the total equity of the banking system, and the first term is the total funding to the banking sector provided by the *outside* claimholders (note that the second term can be written as $\sum_{i=1}^n x_i z_i$). Thus, from equation (2.8) we see the importance of the structure of the financial system for the supply of credit. Ultimately, credit supply to end-users must come either from the equity of the banking system, or the funding provided by non-banks. Greenlaw, Hatzius, Kashyap and Shin (2008) uses this framework to calibrate the

Assets	Liabilities
Loans to firms, households	Liabilities to non-banks (e.g. deposits)
Claims on other banks	Liabilities to other banks
	Equity

Individual bank

Figure 2.2: Balance Sheet of Individual Bank

aggregate consequences of banking sector lending contraction that results from the combination of capital losses and deleveraging from subprime losses.

The aggregate balance sheet identity of the financial intermediary sector given by (2.8) can be explained more informally as follows. Take the balance sheet of an individual bank, given by Figure 2.2. The bank has assets against ultimate borrowers (loans to firms and households), but it also has assets that are claims against other banks. On the liabilities side, the bank has obligations to outside creditors (such as retail depositors), but it also has obligations to other banks.

Now, consider the aggregate balance sheet of the banking sector as a whole, where the assets are summed across individual banks and the liabilities are summed across the banks, also. Every liability that a bank has to another bank is an asset when viewed from the point of view of the lending bank. One asset cancels out another equal and opposite liability. In aggregate, all the claims and obligations across banks cancel out. Thus, in aggregate, the assets of the banking sector as a whole against other sectors of the economy consists of the lending to non-bank borrowers. This lending must be met by two sources - the total equity of the banking system, and the liabilities that banks have to lenders *outside* the banking system. Figure 2.3 illustrates.

Assets	Liabilities
Total lending to ultimate borrowers (firms, households govt)	<div style="border: 1px solid green; padding: 2px; display: inline-block;"> Total debt liabilities to non-banks </div> Total equity

Banking sector

Figure 2.3: Aggregate Balance Sheet of Banking Sector

Equation 2.8 is a statement of the aggregate balance sheet identity. What is useful is the fact that equation 2.8 tells us how the leverage of the financial intermediary sector as a whole depends on the leverage of the individual institutions.

$$\underbrace{\sum_{i=1}^n y_i}_{\text{Total lending to ultimate borrowers}} = \underbrace{\sum_{i=1}^n e_i z_i (\lambda_i - 1)}_{\text{Total debt liabilities To non-banks}} + \underbrace{\sum_{i=1}^n e_i}_{\text{Total equity of intermediaries}}$$

The total debt liabilities of the banking sector to the household creditors can be expected to be sticky, and would be related to total household assets. Thus, the expression in the red balloon above will be slow-moving, in line with shifts in the total household holding of debt claims on the banking sector. For the purposes of short-term comparative statics, we could treat it as a constant. If we treat the expression in the red balloon as a constant, we learn much about the impact of various shifts in the parameters on the configuration of the financial system. We now examine two scenarios.

2.1. Boom Scenario

Consider a boom scenario where the marked-to-market equity of the banks are healthy (that the profile of equity $\{e_i\}$ is strong) and the decline in measured risks leads to an increase in leverage, $\{\lambda_i\}$. In order for the expression in the red balloon to remain constant, there must be an overall decline in $\{z_i\}$, the proportion of funding coming from outside claimholders. In other words, banks must lend more to each other in order to achieve their desired risk-taking profile and leverage, given their strong capital position. In such a scenario, banks take on more of each others' debts and the intertwining of claims and liabilities become more far-reaching. The image is of an increasingly elaborate edifice built on the same narrow foundation, so that the structure becomes more and more precarious. The systemic risks therefore increase during the boom scenario.

Figure 2.4 is the map of CoVaR measures for the conditional Value at Risk for US financial institutions (conditional on distress of another institution) (Adrian and Brunnermeier (2009), IMF (2009)). Andy Haldane (2009) has recently highlighted the highly interconnected nature of financial institutions in the run-up to the financial crisis.

Our accounting identity above shows why such closely interconnected balance sheets is a necessary feature of a boom scenario when banks have strong capital positions and measured risks are low. For any fixed pool of funding to be drawn from the household sector, any substantial increase in balance sheet size of the financial intermediaries can be achieved only by *borrowing and lending from each other*. The key variables are the $\{z_i\}$, which gives the proportion of funding obtained from outside the intermediary sector. In order to increase the profile of leverage $\{\lambda_i\}$ within the intermediary sector, the banks must lower the funding profile $\{z_i\}$, since they are competing for the same limited pool of outside funding. The banks can raise their risk exposure to their desired level only by borrowing

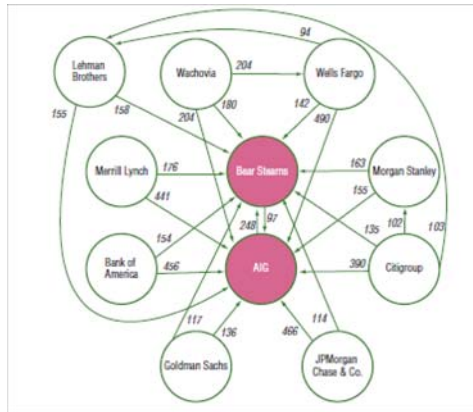

Figure 2.4: US Financial Institutions' Co-Risk Measure (source: IMF Global Financial Stability Report, April 2009)

and lending between themselves, since outside funding is inadequate to meet their growing needs.

An architectural analogy is appropriate. In order to build additional rooms into a house whose footprint is limited by shortage of land, the only way is to build upward - like a skyscraper in Manhattan. The lower is the funding profile $\{z_i\}$, the taller is the skyscraper. However, even this analogy is somewhat misleading in that the Manhattan skyscraper would be planned in advance and built as a coherent whole. An interconnected financial system that builds upward is much less coordinated, and hence is liable to result in greater unintended spillover effects. It would be as if additional floors are built on top of existing ones, where the architects of lower floors did not anticipate further building on top.²

Shortening of maturities would be a natural counterpart to the lengthening intermediation chains. In order for each link in the chain to be a profitable

²Architecturally, the closest example would be the Sutyagin house in Archangel, Russia, reported in the Daily Telegraph of March 7th, 2007. The 13 floor 144 feet wooden structure is described as “a jumble of planking” and the “eighth wonder of the world”. A Google image search for “Sutyagin House” yields dozens of photos of the structure.

leveraged transaction, the funding leg of the transaction must be at a lower interest rate. When the yield curve is upward-sloping, this would entail funding with shorter and shorter maturities at each step in the chain. The prevalence of the overnight repo as the dominant funding choice for securities firms before the current crisis can be understood in this context. The use of ultra-short term debt is part and parcel of long intermediation chains.

The importance of the short-term interest rate in determining the size and fragility of the financial system can be seen from the above line of reasoning. A period of sustained short-term interest rates (with the assurance of continued low short rates by the central bank) is a highly favorable environment for the taking on of such short-term bets. Adrian and Shin (2008) shows that the Fed Funds rate is an important determinant of the growth of securities firms' balance sheets, which in turn has significant effects on the real economy. Thus, there is a monetary policy angle to the increasing length of intermediation chains.

2.2. Bust Scenario

Now consider the reversal of the boom scenario whereby perceptions of heightened risk raise Value at Risk and induce deleveraging of the financial system, leading to lower $\{\lambda_i\}$. In addition, falls in asset prices and possible credit losses eat into the marked-to-market equity levels $\{e_i\}$. This is a double whammy for the financial system as a whole, since in order for the expression in the red balloon to stay roughly constant, there has to be substantial *increases* in $\{z_i\}$. The increase in z_i means that a greater proportion of the funding comes from outside claimholders - that is, the funding that banks had granted to each other must now be withdrawn. This is a classic run scenario where banks run on other banks. The runs on Northern Rock, Bear Stearns and Lehman Brothers are all instances of such a run.

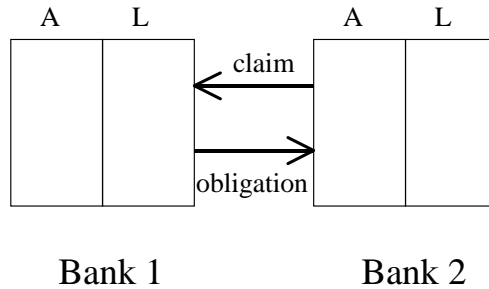

Figure 2.5: Financial Intermediary Run in the Bust Scenario

The direct manifestation of a run of this type can be given a simpler depiction in the following two bank example, taken from Morris and Shin (2008). Bank 1 has borrowed from Bank 2. Bank 2 has other assets, as well as its loans to Bank 1. Suppose that Bank 2 suffers credit losses on these other loans, but that the creditworthiness of Bank 1 remains unchanged. The loss suffered by Bank 2 depletes its equity capital. In the face of such a shock, a prudent course of action by Bank 2 is to reduce its overall exposure, so that its asset book is trimmed to a size that can be carried comfortably with the smaller equity capital.

From the point of view of Bank 2, the imperative is to reduce its overall lending, including its lending to Bank 1. By reducing its lending, Bank 2 achieves its micro-prudential objective of reducing its risk exposure. However, from Bank 1's perspective, the reduction of lending by Bank 2 is a withdrawal of funding. Unless Bank 1 can find alternative sources of funding, it will have to reduce its own asset holdings, either by curtailing its lending, or by selling marketable assets.

In the case where we have the combination of (i) Bank 1 not having alternative sources of funding, (ii) the reduction in Bank 2's lending being severe, and (iii) Bank 1's assets being so illiquid that they can only be sold at fire sale prices, then the withdrawal of lending by Bank 2 will feel like a run from the point of view of

Bank 1. In other words, a prudent shedding of exposures from the point of view of Bank 2 is a run from the point of view of Bank 1. Arguably, this type of run is one element of what happened to Northern Rock, Bear Stearns and Lehman Brothers.

3. Prescriptions

The prescriptions for moderating the fluctuations associated with the boom and busts scenarios can also be understood in terms of the aggregate balance sheet identity (2.8). We discuss three in particular - regulatory interventions, various forms of forward-looking provisioning, and the reform of the institutions involved in financial intermediation.

Approach 1. Regulatory Intervention.

The first approach is to moderate the fluctuations in leverage and balance sheet size through capital regulation with an explicit countercyclical element, such as the countercyclical capital targets advocated in the recent Geneva Report (Brunnermeier et al. (2009)) and the Squam Lake Working Group's memo on capital requirements (Squam Lake Working Group (2009)). The leverage cap introduced in Switzerland recently (Hildebrand (2008)) can also be understood in this connection.

$$\sum_{i=1}^n y_i = \sum_{i=1}^n e_i z_i (\lambda_i - 1) + \sum_{i=1}^n e_i$$

Leverage caps or countercyclical capital targets aim at restraining the growth of leverage $\{\lambda_i\}$ in boom times so that the corresponding bust phase of the financial cycle is less damaging, or can be avoided altogether. In the above expression,

moderating the fluctuations in $\{\lambda_i\}$ implies that the marked-to-market equity values $\{e_i\}$ and the outside financing proportions $\{z_i\}$ can also be kept within moderate bounds, so as to prevent the rapid build-up of cross-exposures which are then subsequently unwound in a disorderly way as runs against other banks.

A closely related set of proposals are those that address the *composition* of assets, rather than the capital ratio. The idea is to impose liquidity requirements on the banks so as to limit the externalities in the bust phase of the cycle. Cifuentes, Ferrucci and Shin (2004) is an early statement of the proposal, subsequently incorporated in the Bank of England's RAMSI framework for systemic risk.³

Morris and Shin (2008, 2009) describe the rationale for liquidity requirements and provides an analysis of the mechanisms invoked. The idea is to take those elements that are responsible for the vicious circle of distress and self-reinforcing runs and then harness them to create a *virtuous circle* of beliefs leading to a stable outcome. Liquidity requirements mandate a cushion of cash assets over some interval of time, such as requiring banks to maintain reserves at the central bank over some fixed maintenance period. Such liquidity requirements can moderate the externalities involved in a run by influencing the risks of spillovers across financial intermediaries. When a borrower bank has a high level of liquidity, then the withdrawal of funding by its creditor banks can be met (at least partly) by its liquid resources, which makes the debtor bank less likely to run on other banks. For creditor banks, there are two effects. First, knowing that the debtor bank is less vulnerable to runs reduces the incentive to run that arises purely from a coordination motive. In addition, when each creditor bank realizes that other creditor banks have higher liquidity levels, the coordination problem among the

³The Bank of England's RAMSI framework is described in the recent issue of the IMF's Global Financial Stability Report (2009, chapter 2).

creditor banks becomes less sensitive to strategic risk - making them less jittery when faced with a run scenario. The more relaxed attitude of creditors and debtors are mutually reinforcing, just in the same way that distress and concerns about others' viability can be self-reinforcing. In this way, the same forces that lead to the vicious circle of run psychology can be harnessed and channeled to generate a *virtuous circle* of stability.

Approach 2. Forward-Looking Provisioning.

A second way to moderate fluctuations of the boom bust cycle is to operate directly on the equity $\{e_i\}$ of the banks. The forward-looking statistical provisioning scheme that has operated in Spain is a good example of such a method. By imposing a provisioning charge when new loans are made, there is a corresponding diminution of the equity level of the bank making the loan. For any given desired leverage of the bank, a lower equity level means lower total assets, hence restraining the rapid growth of balance sheets.

$$\sum_{i=1}^n y_i = \sum_{i=1}^n e_i z_i (\lambda_i - 1) + \sum_{i=1}^n e_i$$

The Spanish pre-provisioning scheme highlights one of the important lessons in a boom⁴. Under a boom scenario, the problem is that there is *too much equity* in the banking system. There is overcapacity in the sense that the level of aggregate capital is too high. Capital is higher than is consistent with only prudent loans being made. Overcapacity leads to the chasing of yields and the lowering of credit standards. Elsewhere (Shin (2009)), I have sketched a mechanism for the emergence of subprime lending based on this mechanism. Expanding balance

⁴For a description of the Spanish pre-provisioning system, see the Bank of Spain working paper by Fernandez, Pages and Saurina (2000).

sheets are like an expanding balloon. Just as an expanding balloon needs air to fill the balloon, expanding balance sheets need new asset creation. But when all prime mortgage borrowers are already catered for, lending standards must be lowered in order to generate new assets. Hence, subprime lending emerges as a result of the urge to expand balance sheets.

In the Geneva Report, we discuss the merits of a variant of the Spanish provisioning scheme called the Pigovian Tax. The idea is that rather than reducing equity through a provision, equity can also be lowered in a boom through an explicit centralized tax. The tax has the potential to enhance efficiency of the overall financial system in the same way that a congestion charge would improve traffic in a city. By counteracting an existing inefficiency through a tax, one can counteract the harmful externality. Just as with a traffic congestion charge, the revenue raised in the tax is not an essential component of the scheme. However, if the revenue raised through the Pigovian Tax could be put into a separate bank resolution fund, then the scheme would not imply a net transfer away from the banking sector.

Approach 3. Structural Reform of Intermediation.

A third approach is more long term, and is aimed at influencing the market structure of the financial intermediary sector as a whole. The idea is to restrain the lengthening of intermediation chains, and encourage the formation of shorter intermediation chains.

$$\sum_{i=1}^n y_i = \sum_{i=1}^n e_i z_i (\lambda_i - 1) + \sum_{i=1}^n e_i$$

In terms of the aggregate balance sheet identity, the objective is to operate directly on the mode of financial intermediation so that the funding profile $\{z_i\}$

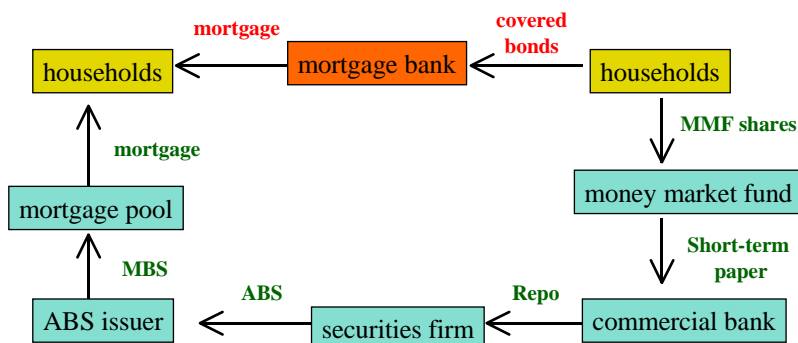

Figure 3.1: Shortening the Intermediation Chain through Covered Bonds

is maintained at high levels, thereby limiting the number of intermediaries n and moderating the fluctuations in leverage and total assets. The idea is to induce a shortening of the financial intermediation chain by linking ultimate borrowers and ultimate lenders more directly.

One potential way to induce such shortening of the intermediation chain would be through the encouragement of the issuance of covered bonds – bonds issued against segregated assets on a bank’s balance sheet, with recourse against the issuing bank itself.

The intermediation chain associated with a covered bond is short, since the bank holds mortgage claims against ultimate borrowers, and issues covered bonds that could be sold directly to households or to long-only institutions such as mutual funds or pension funds. The bonds offer longer duration that match the duration of the assets. The longer duration of the liabilities have two advantages. First, the duration matching between assets and liabilities means that the issuing bank does not engage in maturity transformation in funding. Rigorous application of marking to market makes less sense when loans are segregated to back such liabilities. In the Geneva Report, we have argued that the accounting treatment

of such assets can take account of what the banks are capable of holding, rather than simply appealing to their intentions, as is the rule under the current market-to-market regime .

Second, the fact that liabilities have long duration means that the short-term funding that is prevalent in the long intermediation chains will be less likely to be employed provided that the covered bonds are held directly by households or by long-only institutions such as pension funds and mutual funds. The long duration of such securities would be a natural source of sought-after duration for pension funds who wish to match the long duration of their pension liabilities. Household savers would also find such products a good substitute for government bond funds. The shortening of the intermediation chain in this way will have important benefits in terms of mitigating the fluctuations in leverage and balance sheet size in the financial boom bust cycle.

Covered bonds have been a familiar feature of many European countries, especially in Denmark (with its mortgage bonds) and Germany (with its pfandbriefe). But to date, over twenty countries in Europe have some form of covered bonds backed by laws that underpin their role in the financial system. Packer, Stever and Upper (2007) is a recent overview of the covered bond system, who report that as of mid-2007 the outstanding amount of covered bonds reached €1.7 trillion.

As already discussed, covered bonds are securities issued by a bank and backed by a dedicated, segregated group of loans known as a “cover pool”. The bondholders have two safeguards in their holding of covered bonds. First, the bonds are backed by the cover pool over which the bondholders have senior claims in case of bankruptcy. Second, because the covered bonds are the obligations of the issuing bank, the bondholders have recourse to the bank if the cover pool is insufficient to meet the bond obligations. In this second sense, covered bonds differ from the U.S.-style mortgage backed security, which are obligations of the

special purpose vehicle - a passive company whose sole purpose is to hold assets and issue liabilities against those assets. The loans backing the covered bonds stay on the balance sheet of the bank, eliminating one step in the intermediation chain, and also guarding against potential incentive problems in the “originate to distribute” model of securitization in which the originating bank can sell the loan and take it off its balance sheet altogether.

The double protection offered by covered bonds distinguishes them both from senior unsecured debt and asset-backed securities (ABSs). In contrast to ABSs, the cover pool serves mainly as credit enhancement and not as a means to obtain exposure to the underlying assets. Also, cover pools tend to be dynamic in the sense that issuers are allowed to replace assets that have either lost some quality or have been repaid early. These features imply that covered bonds are seen not so much as an instrument to obtain exposure to credit risk, but rather as a higher-yielding alternative to government securities.

These payoff attributes of covered bonds are reflected in the identity of the investors who hold them. The identity of the investors are critical in determining the funding profile $\{z_i\}$ of the intermediation sector. The objective of achieving a higher funding profile is achieved if the investors are either household savers or non-bank institutions such as pension funds and mutual funds. A survey of the investors in covered bonds was released in May 2009 by the European Covered Bond Dealers Association (SIFMA (2009)), and is reproduced in Figure 3.2. We see that the bulk of the investors in covered bonds are non-banks, with the largest category being asset management firms. Leveraged institutions and intermediaries constitute only around one third of the total. Even within the intermediary sector, institutions such as private banks are closer to asset management firms in character than intermediaries such as broker dealers who lengthen the intermediation chain.

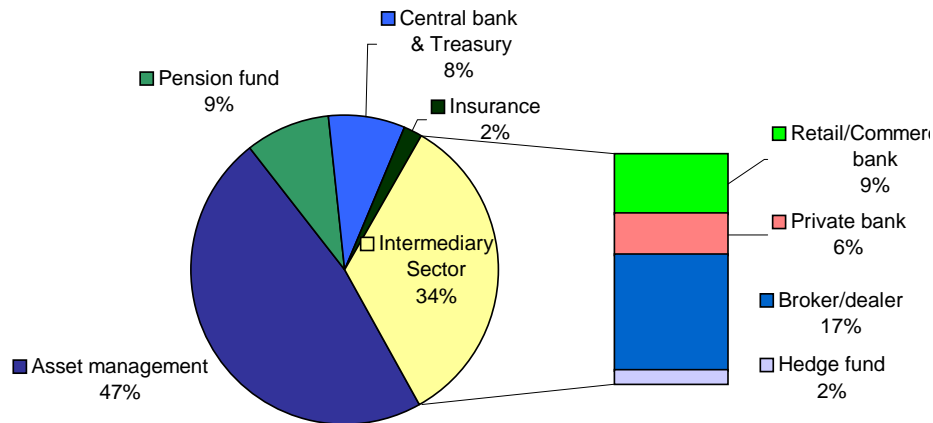

Figure 3.2: Investors in covered bonds (source: SIFMA (2009))

Even among covered bonds, the Danish system of mortgage bonds has attracted considerable attention recently as a resilient institutional framework for household mortgage finance due to the added feature that household mortgage borrowers can redeem their debt by purchasing the relevant issue of the mortgage bonds at the prevailing market price (see Boyce (2008)). By being able to extinguish debt obligations at market prices, household borrowers participate as purchasers in the market for mortgage debt, and prevent the type of collapse in mortgage-backed securities seen in the United States in the financial crisis of 2007 and 2008.

The legislation required to underpin the operation of a covered bond system is more developed in some regions than others. Europe leads the world in this respect. In the European Union, covered bonds are defined by the Capital Requirements Directive (CRD), which limits the range of accepted collateral maximum loan-to-value ratios. While the CRD only recognizes securities issued under special legislation as covered bonds, market participants tend to work with

a more general definition that also includes bonds issued under private contractual arrangements using elements from structured finance. There have been a number of such “structured covered bonds”, primarily in countries without covered bond legislation (eg the United Kingdom, the Netherlands and the United States) (see Packer, Stever and Upper (2007)).

Indeed, one of the main hurdles against the widespread introduction of a covered bond system has been the legal hurdle of introducing a class of claimholders for the cover pool that are senior to the deposit insurance agency, and hence the general depositors of the bank. The larger is the cover pool for covered bonds, the smaller is the general pool of assets that are accessible to the deposit insurance agency. In the United States, the FDIC has issued a statement on the treatment of covered bonds, limiting the size of covered bonds to 4% of total liabilities after issuance.⁵ Given the benefits associated with the shortening of the intermediation chain, there are legitimate questions on how much political will can be mustered in order to amend the relevant laws to allow the operation of the covered bond system.

A possible alternative legal approach would be to permit specialist “narrow” banks whose liabilities are restricted to covered bonds only, and hence whose liabilities are not insured by the deposit insurance agency. Such narrow banks would be akin to Danish mortgage banks whose liabilities match the duration of the assets perfectly and whose equity provides a cushion for bond holders.

4. Implications for Korea

Korea has been vulnerable to “twin crises” in which a banking crisis and currency crisis reinforce each other. Such crises are particularly potent due to the mutu-

⁵The FDIC’s statement on covered bonds is at <http://www.fdic.gov/news/news/financial/2008/fi108073.html>

ally reinforcing nature of the two crises, and the rapid deterioration of economic fundamentals caused by the amplification of the crisis. Although twin crises show many different forms across countries and across time, the common thread that links all of them is the balance sheet mismatch at the aggregate country level arising from excessive short-term debt denominated in foreign currency.

There are three potential ways to address the vulnerability to twin crises:

- maintain larger holding of foreign exchange reserves
- curb the growth of banking sector assets
- diversify the funding sources for the banking sector.

However, the first two methods have many undesirable economic consequences and are unsuitable as a long-term strategy for financial sector resilience. The best way to improve the resilience of the Korean financial sector is through the third method – to diversify the funding sources for the banking sector. US-style securitization has been shown to be flawed in the current crisis. Instead, the adoption of “covered bonds” (used in Europe for over two hundred years) is a more promising long-term strategy to diversify the funding of the banking sector while maintaining the stability of the system.

Foreign exchange reserves held by Korea rose to \$227 billion in May, up substantially from last autumn in the midst of the liquidity crisis caused by the failure of Lehman Brothers. There is an active debate on the appropriate size of foreign exchange reserves, with some voices arguing for a continued accumulation of foreign exchange reserves. Although larger foreign exchange reserves may be desirable in the short-term, maintaining large foreign exchange reserves is not a feasible or desirable option for Korea in the long-term.

Maintaining large reserves is costly – it is tantamount to lending to foreigners at a very low interest rate. Given the large and growing US budget deficit and the

potential for a rapid fall in the value of the US dollar, there is the potential for large capital losses on such holdings. Large reserves hinder the smooth functioning of domestic monetary policy pursued by the Bank of Korea, as capital inflows have to be sterilized by issuing domestic claims. Capital inflows present challenges for maintaining domestic liquid reserves at prudent levels. Finally, there are international political economy issues. Large foreign exchange reserves expose Korea to political pressures from US politicians who may misinterpret Korea's intentions, and accuse it of artificially maintaining a weak currency.

For these reasons, maintaining large foreign exchange reserves is not a desirable long-term strategy. Much better would be to reduce the vulnerability of the Korean financial sector, so that there is less need to hold large foreign exchange reserves.

One potential way to reduce the vulnerability of the Korean financial sector is by curbing the rapid growth of lending in booms. Restricting the rapid growth of assets would mitigate the building up of such vulnerabilities, but such a policy also carries large costs. By restricting the growth of assets, lending would be limited to the same rate as the growth of retail deposits. However, for a rapidly growing economy, such restrictions would impose inefficiently tight restrictions on loans.

There is also the danger that banks would focus excessively on the availability of collateral, so that lending is skewed toward residential real-estate based lending, at the expense of financing for firms. Although large companies can tap the capital markets, the same is not true of the small and medium sized enterprises (SMEs) who rely heavily on bank lending. Therefore, restricting the growth of assets will have potentially undesirable side-effects of choking off lending to SME firms.

These concerns are magnified by the institutional development in which banks have to compete to keep their retail deposits in the face of competition from

other providers of deposit-like savings instruments, such as money market funds (MMFs) provided by securities firms. Restricting the excessive growth of bank lending should form part of the overall strategy for the Korean financial sector, but relying on it exclusively will entail undesirable costs. Combining such a policy with a long-term policy for the diversification of bank funding is important. I turn to this issue now.

US-style securitization in which loans are sold off to special purpose vehicles has been shown to be flawed by the current crisis. Securitization was meant to disperse risks associated with bank lending so that deep-pocketed investors who were better able to absorb losses would share the risks. But as argued already, in reality, securitization had the perverse effect of concentrating all the risks in the banking system itself. The severity of the global financial crisis, especially in the United States, highlights the shortcomings of US-style securitization and the excessive growth of the securities industry relative to the real economy.

One promising alternative to US-style securitization is the institution of covered bonds. Covered bonds offer two main benefits. First, by providing a long-term domestic source of funding for the banking system, the liability structure of the banking sector is made more resilient. The funding becomes (i) long-term and (ii) denominated in the domestic currency. For both reasons, covered bonds guard against twin crises of liquidity crisis and currency crisis. Second, covered bonds provide a long-term savings vehicle for households that (in contrast to bank deposits) allow them to hedge against fluctuations in interest rates. The legislation required to underpin the operation of a covered bond system is most developed in the European Union. Outside Europe, the main hurdle against the widespread introduction of a covered bond system is the legal hurdle of introducing a class of claimholders for the cover pool that are senior to the deposit insurance agency, and hence the general depositors of the bank. However, given the large benefits from

providing a stable source of domestic funding and providing a long-term savings vehicle, the development of the covered bond system deserves greater attention from policy makers.

A possible way to overcome the issue of seniority of depositors is to establish specialist "narrow" banks whose liabilities are restricted to covered bonds only, and hence whose liabilities are not insured by the deposit insurance agency. Danish mortgage banks operate in this way. Indeed, Denmark provides a good illustration of how resilience of the financial sector can be combined with active lending for domestic mortgage borrowers. Denmark's housing boom was almost as large as that of the United States. However, Denmark has not seen a similar financial crisis as in the United States. This contrast is largely due to the difference in the financial structure and the operation of the covered bond system.

For Korea, the covered bond system in Denmark (but also in Germany, France, Spain and others) would bring the twin advantages of providing a stable source of long-term domestic funding, and the provision of a long-term savings vehicle for households.

5. Concluding Remarks

The organizing theme of this paper has been the overall systemic impact of long versus short intermediation chains. Long intermediation chains have been associated with the rapid development of the securitized, market-based financial system in the United States. I have argued that long intermediation chains carry costs in terms of greater amplitude of fluctuations in the boom bust cycle of leverage and balance sheet size. Shorter intermediation chains carry benefits for stability of the financial system.

For the financial industry, the key question is to what extent the rapid development of securitization and the market-based system can be regarded as the

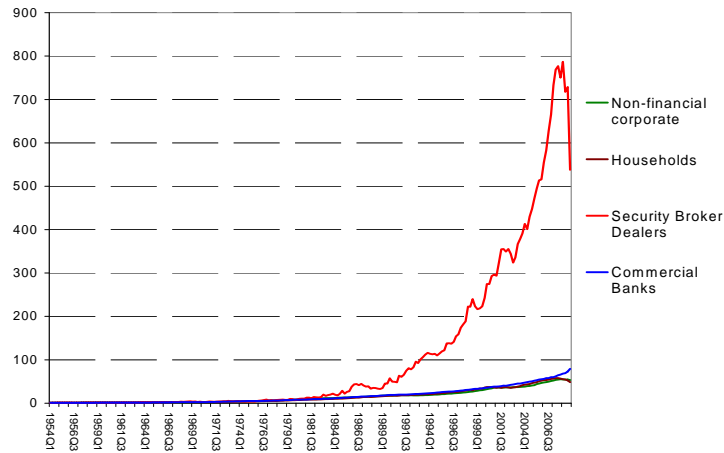

Figure 5.1: Growth of Four US Sectors (1954Q1 = 1) (source: Flow of Funds, Federal Reserve)

norm, or a long, but ultimately temporary stage in the development of a more sustainable financial system. Figures 5.1 and 5.2 show the growth of four sectors in the United States (non-financial corporate sector, household sector, commercial banking sector and the security broker-dealer sector) taken from the Federal Reserve's Flow of Funds accounts. The series are normalized so that the size in Q1 1954 is set equal to 1. Most sectors grew to roughly 80 times its size in 1954, but the broker dealer sector grew to around 800 times its 1954 level, before collapsing in the current crisis. Figure 5.2 is the same chart, but in log scale. The greater detail afforded by the chart in log scale reveals that the securities sector kept pace with the rest of the economy until around 1980, but then started a growth spurt that outstripped the other sectors. On the eve of the crisis, the securities sector had grown to around ten times its size relative to the other sectors in the economy. Clearly, such a pace of growth could not go on forever. Even on an optimistic scenario, the growth of the securities sector would have tapered off to a

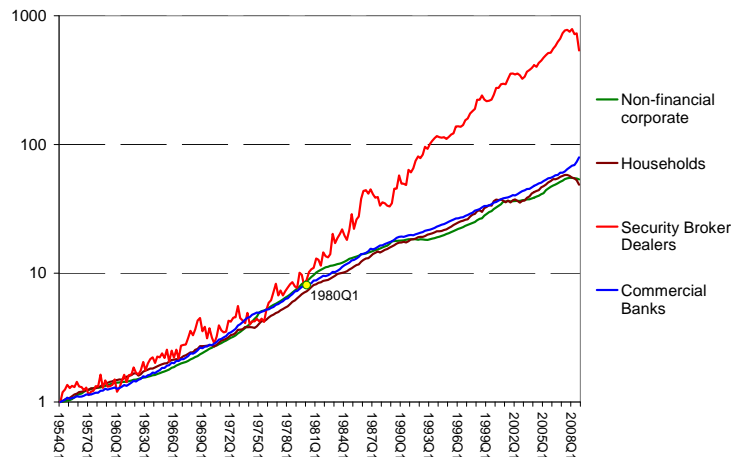

Figure 5.2: Growth of Four US Sectors (1954Q1 = 1) (in log scale)

more sustainable pace to keep in step with the rest of the economy.

The relative size of the securities sector can be seen as a mirror of the lengthening intermediation chains in the market-based system of financial intermediation. One could reasonably conclude that some of the baroque flourishes that appeared in the Indian summer of the expansion of the securities sector (such as the growth of exotic asset-backed securities such as CDO-squared) have gone for good, and are unlikely to feature in a steady state of the securities sector.

Overall, it would be reasonable to speculate that the securities sector that emerges from the current crisis in sustainable form will be smaller, with shorter intermediation chains, perhaps less profitable in aggregate, and with less maturity transformation. The backdrop to this development will be the regulatory checks and balances that are aimed at moderating the fluctuations in leverage and balance sheet size that were instrumental in making the current financial crisis the most severe since the Great Depression.

References

Adrian, Tobias and Markus Brunnermeier (2009) “CoVaR” working paper, Federal Reserve Bank of New York and Princeton University

Adrian, Tobias and Hyun Song Shin (2007) “Liquidity and Leverage” forthcoming in the *Journal of Financial Intermediation*

Adrian, Tobias and Hyun Song Shin (2008) “Financial Intermediaries, Financial Stability and Monetary Policy” Proceedings of the Federal Reserve Bank of Kansas City Symposium at Jackson Hole, 2008.

Adrian, Tobias and Hyun Song Shin (2009) “Money, Liquidity and Monetary Policy” forthcoming in *American Economic Review*, Papers and Proceedings

Boyce, Alan (2008) “Covered Bonds vs. Securitization Transparency vs. Opacity Which is the Right Question” working paper, Absalon
https://www.ibm.com/developerworks/blogs/resources/adler/20090325_1.pdf

Brunnermeier, Markus (2009) “De-Ciphering the Credit Crisis of 2007” *Journal of Economic Perspectives*, 23(1), 77-100

Brunnermeier, Markus, Andrew Crockett, Charles Goodhart, Avi Persaud and Hyun Song Shin (2009) “The Fundamental Principles of Financial Regulation” Geneva Report on the World Economy 11.

Calomiris, Charles and Charles Kahn (1991) “The Role of Demandable Debt in Structuring Optimal Banking Arrangements” *American Economic Review*, 81, 497-513

Cifuentes, Rodrigo, Gianluigi Ferrucci and Hyun Song Shin (2004) “Liquidity Risk and Contagion” Bank of England working paper 264, short version published in *Journal of the European Economic Association*, 3, 556-566 (2005)
<http://www.bankofengland.co.uk/publications/workingpapers/wp264.pdf>

Diamond Douglas and Raghuram Rajan (2001) “Liquidity Risk, Liquidity Creation, and Financial Fragility: A Theory of Banking” *Journal of Political Economy*, 109, 287-327.

Fernandez, S., J. Pages and J. Saurina (2000) “Credit Growth, Problem Loans and Credit Risk Provisioning in Spain” Bank of Spain working paper 18, <http://www.bde.es/informes/be/docs/dt0018e.pdf>

Greenlaw, D., J. Hatzius, A. Kashyap and H. S. Shin (2008) “Leveraged Losses: Lessons from the Mortgage Market Meltdown” US Monetary Policy Forum Report 2, <http://www.chicagogsb.edu/usmpf/docs/usmpf2008confdraft.pdf>

Haldane, Andrew (2009) “Rethinking Financial Networks” Speech delivered at Financial Student Association in Amsterdam 28 April 2009 <http://www.bankofengland.co.uk/publications/speeches/2009/speech386.pdf>

Hildebrand, Philipp (2008) “Is Basel II enough? The benefits of a leverage ratio” Financial Markets Group Lecture, www.bis.org/review/r081216d.pdf

International Monetary Fund, (2009), Global Financial Stability Report, April, Washington DC

Morris, Stephen and Hyun Song Shin (2008) “Financial Regulation in a System Context,” *Brookings Papers on Economic Activity*, Fall 2008, 229-274.

Morris, Stephen and Hyun Song Shin (2009) “Illiquidity Component of Credit Risk” working paper, Princeton University.

Packer, F., R. Stever and C. Upper (2007) “The Covered Bond Market” *BIS Quarterly Review*, September 2007, 43-55.

Shin, Hyun Song (2009) “Securitisation and Financial Stability” *Economic Journal*, 119, 309 – 332.

SIFMA (2009) *First European Covered Bond Investors’ Survey*, European Covered Bond Dealers Association, May 2009, <http://europe.sifma.org/ecbda.shtml>

Squam Lake Working Group (2009) “Reforming Capital Requirements for Financial Institutions” policy memo, <http://www.squamlakeworkinggroup.org/>

Financial Intermediation and the Post-Crisis Financial System with Implications for Korea

Hyun Song Shin

2009 KDI Journal of Economic Policy Conference

KDI, August 7th 2009

Outline

- Lessons on financial system architecture from global financial crisis
- General implications for
 - Size of financial sector relative to real economy
 - Securitization
 - Financial regulation
- Implications for Korea
 - Stability of bank funding
 - FX reserves

Stylized Financial System

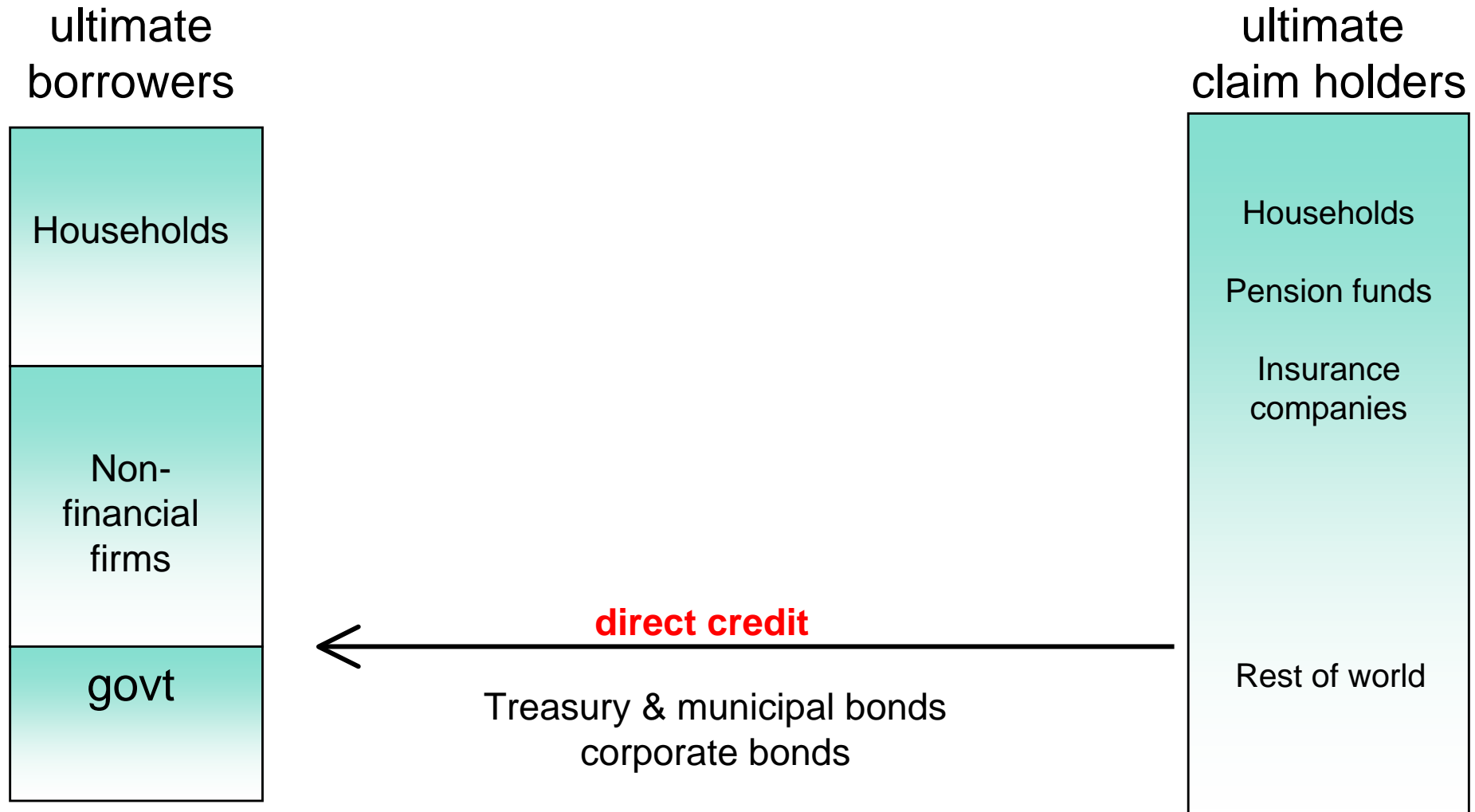

Stylized Financial System

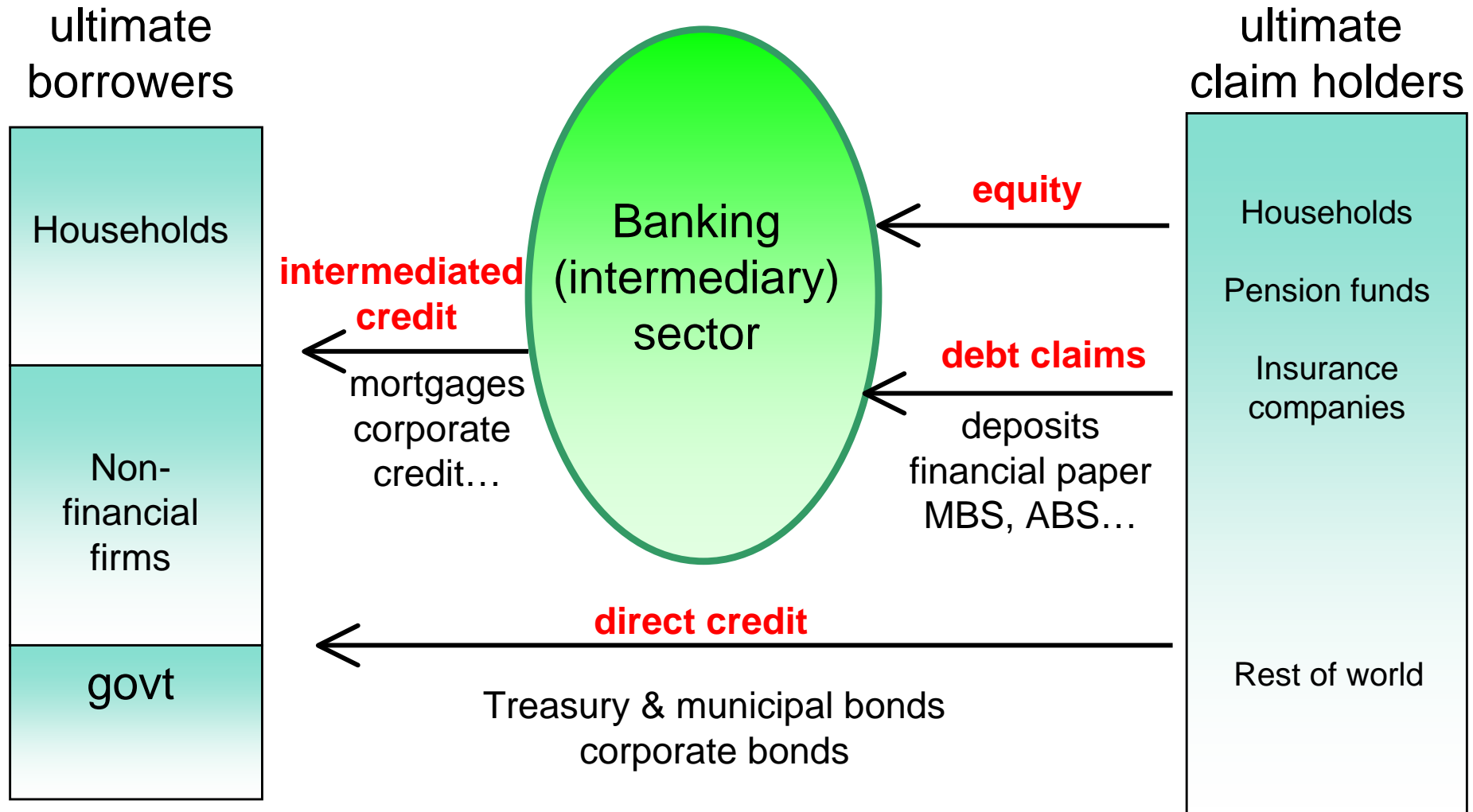

Stylized Financial System

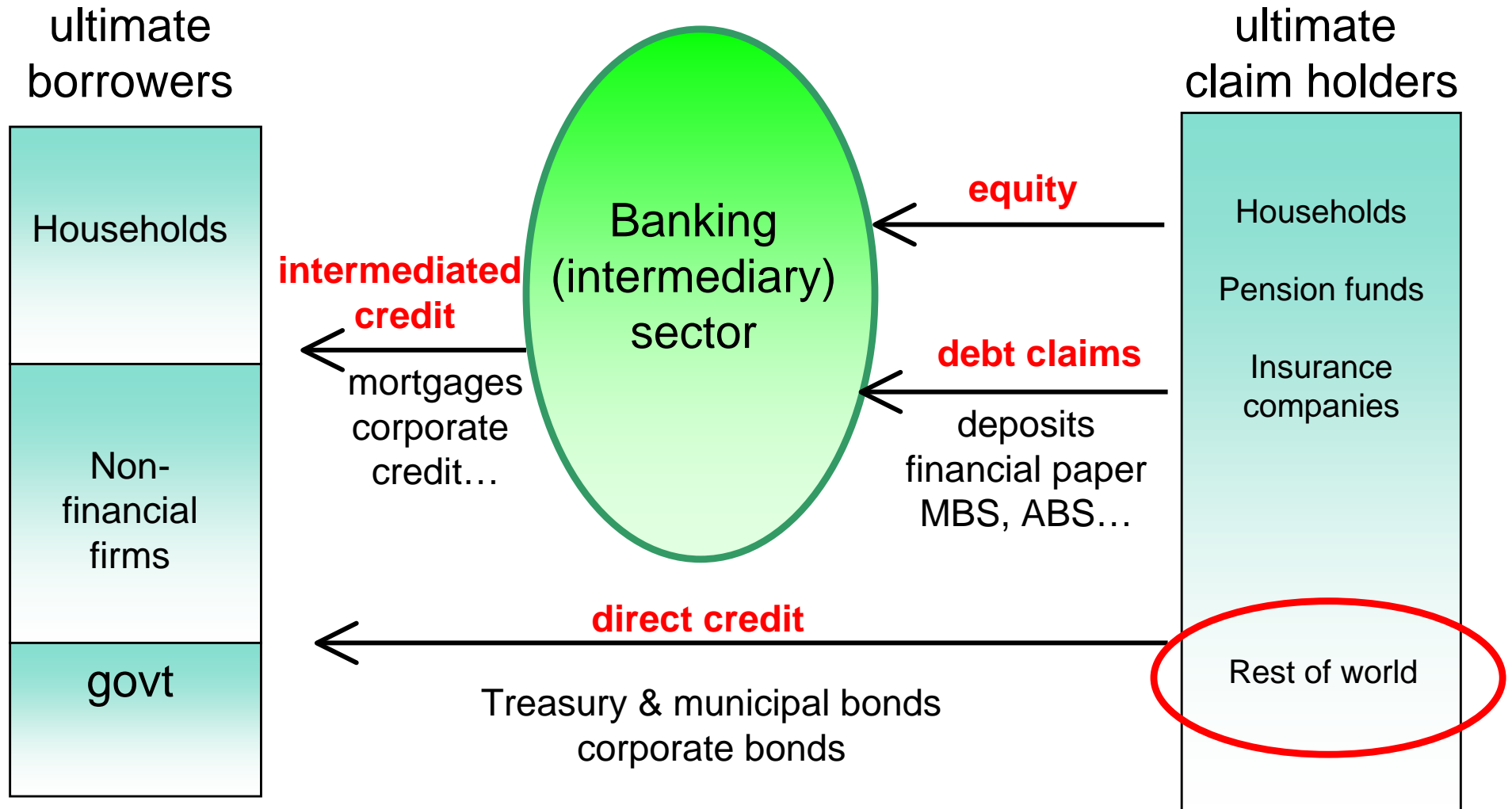

Boom Scenario

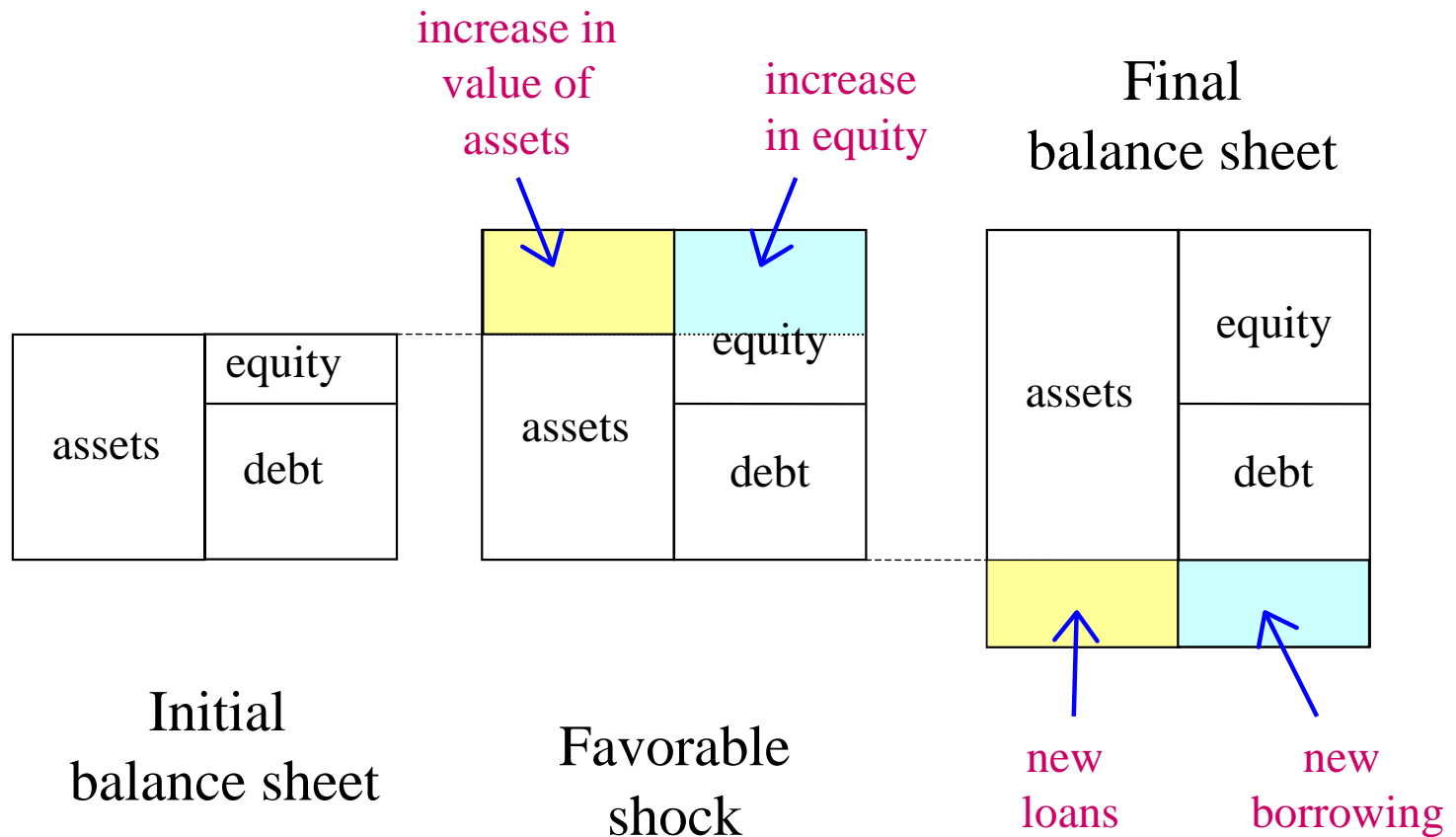

Composition of Northern Rock's Liabilities

(June 1998 - June 2007)

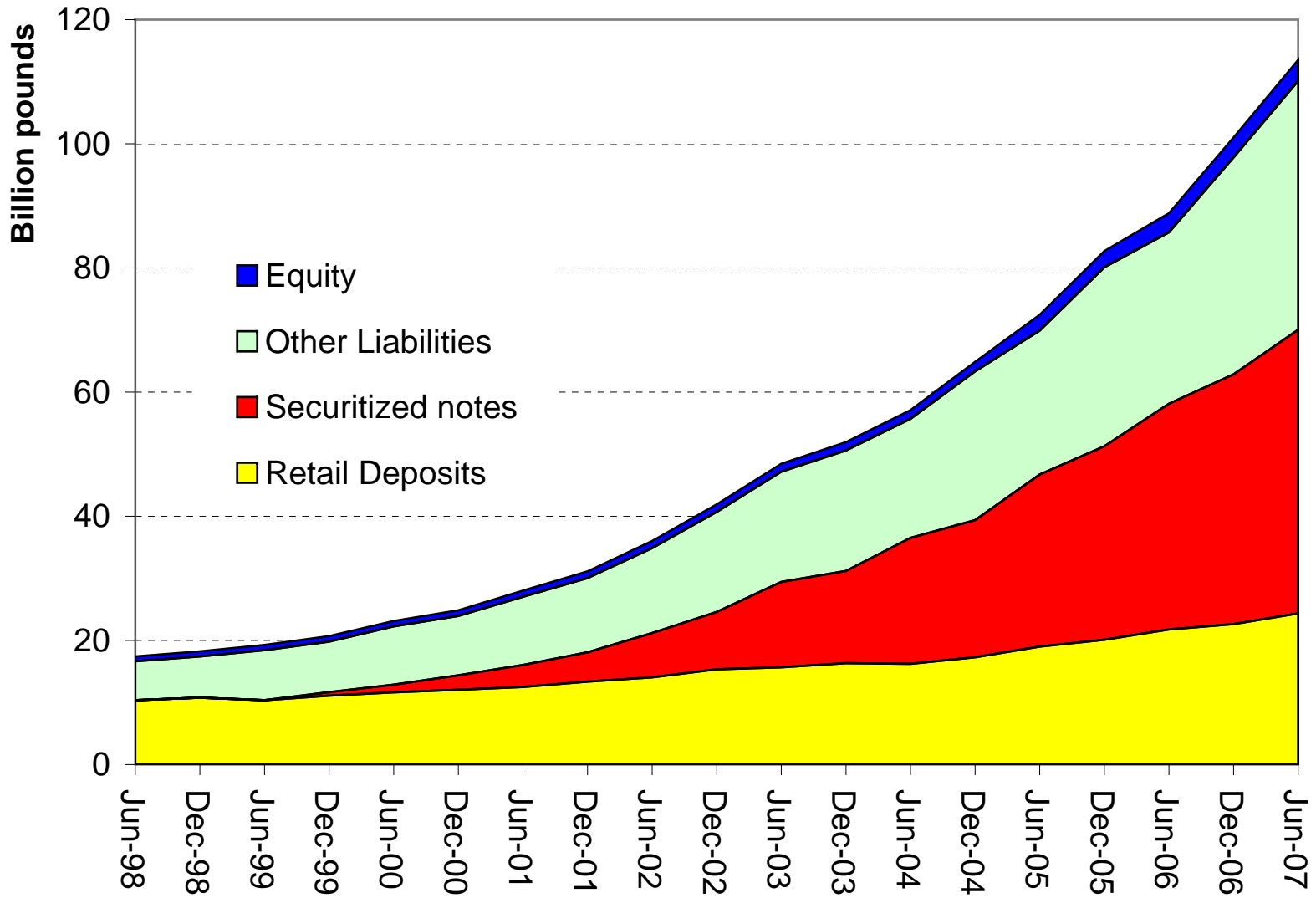

Currency (Mis)match

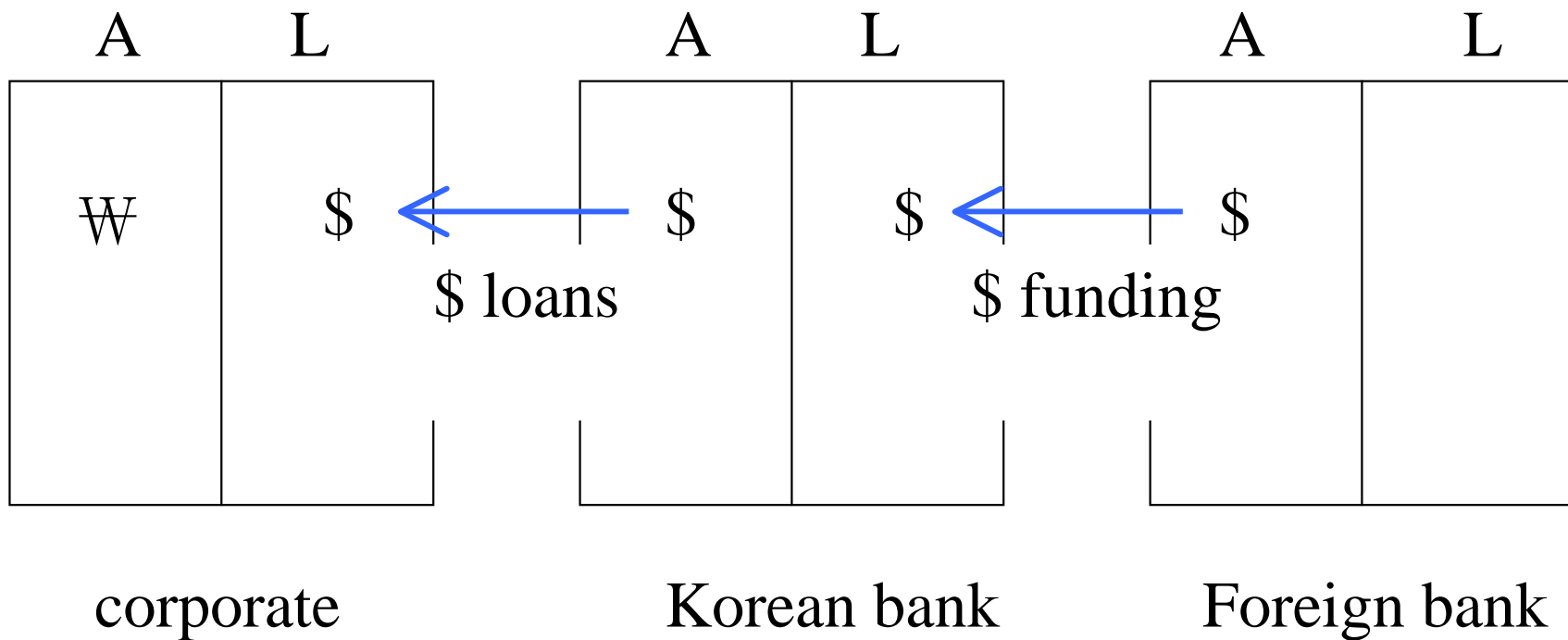

Currency (Mis)match

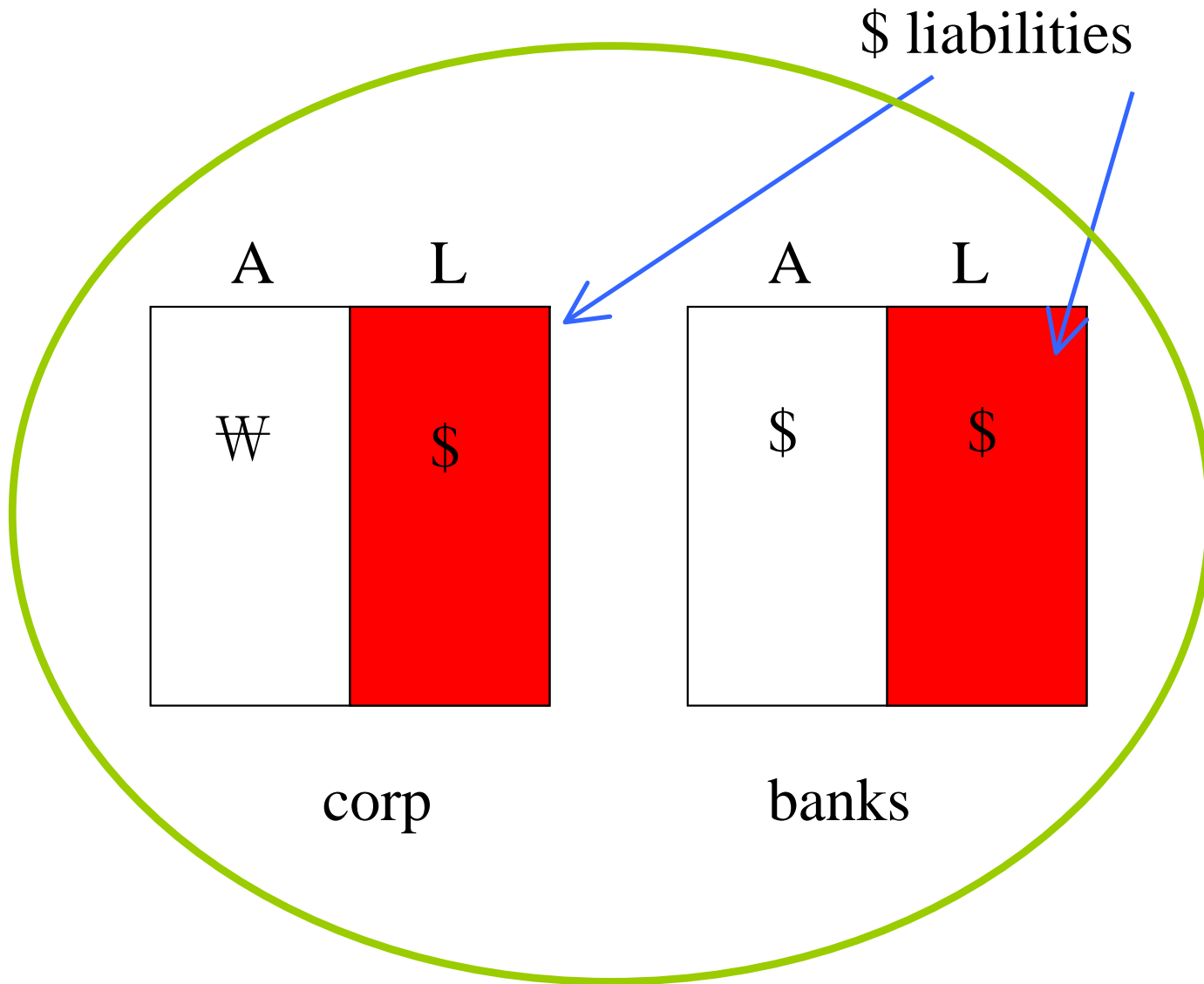

Banks have matching balance sheets, but not private sector as whole

Asset-backed Commercial Paper Outstanding

(19 July 06 - 16 July 08, weekly)

Source: Federal Reserve

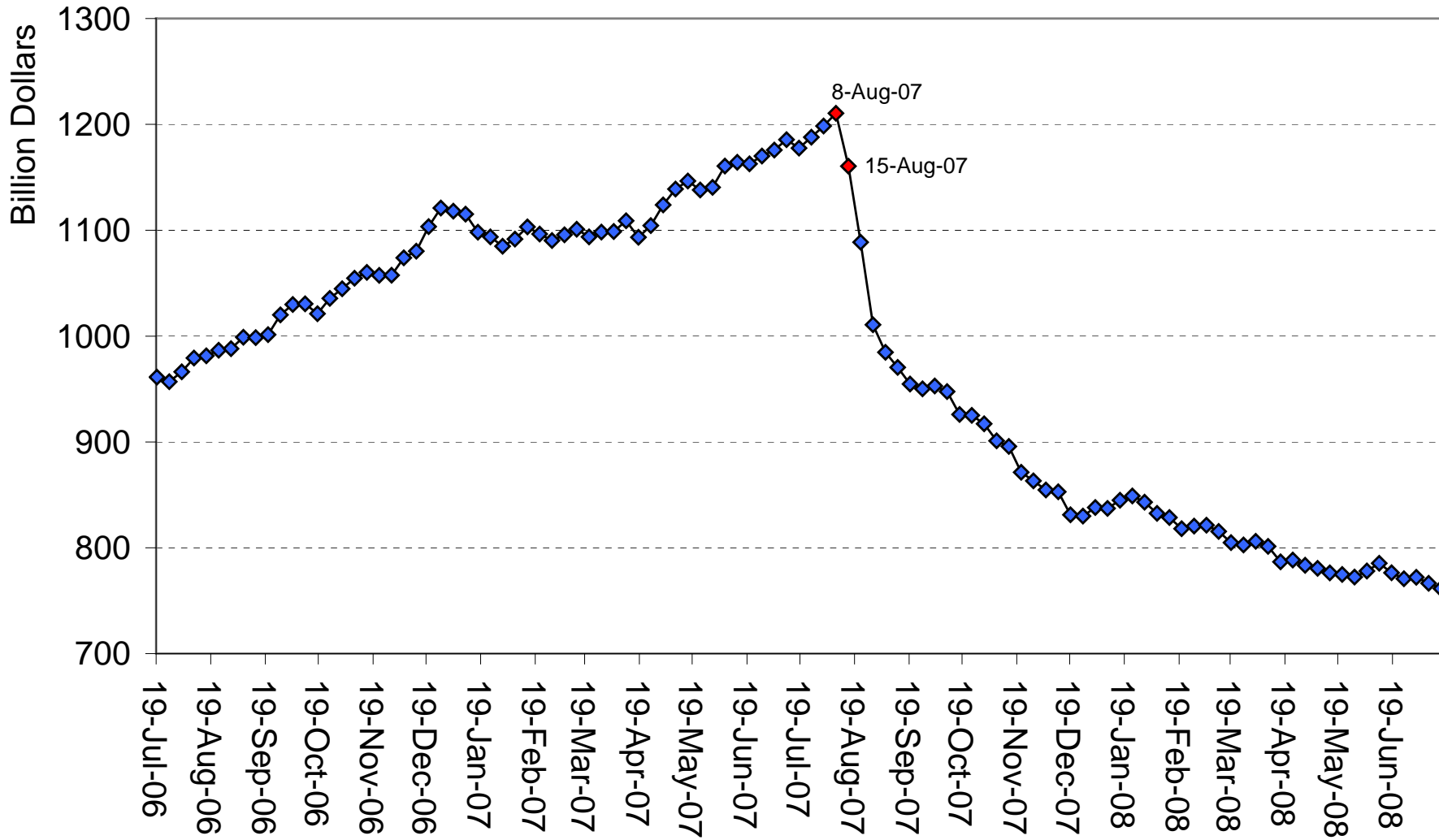

Three Possible Remedies

- Build up FX reserves
- Restrain asset growth to match deposit growth
- Structural improvements in funding

Securitization and Financial Development

US Financial Intermediaries Total Assets (2007Q2)

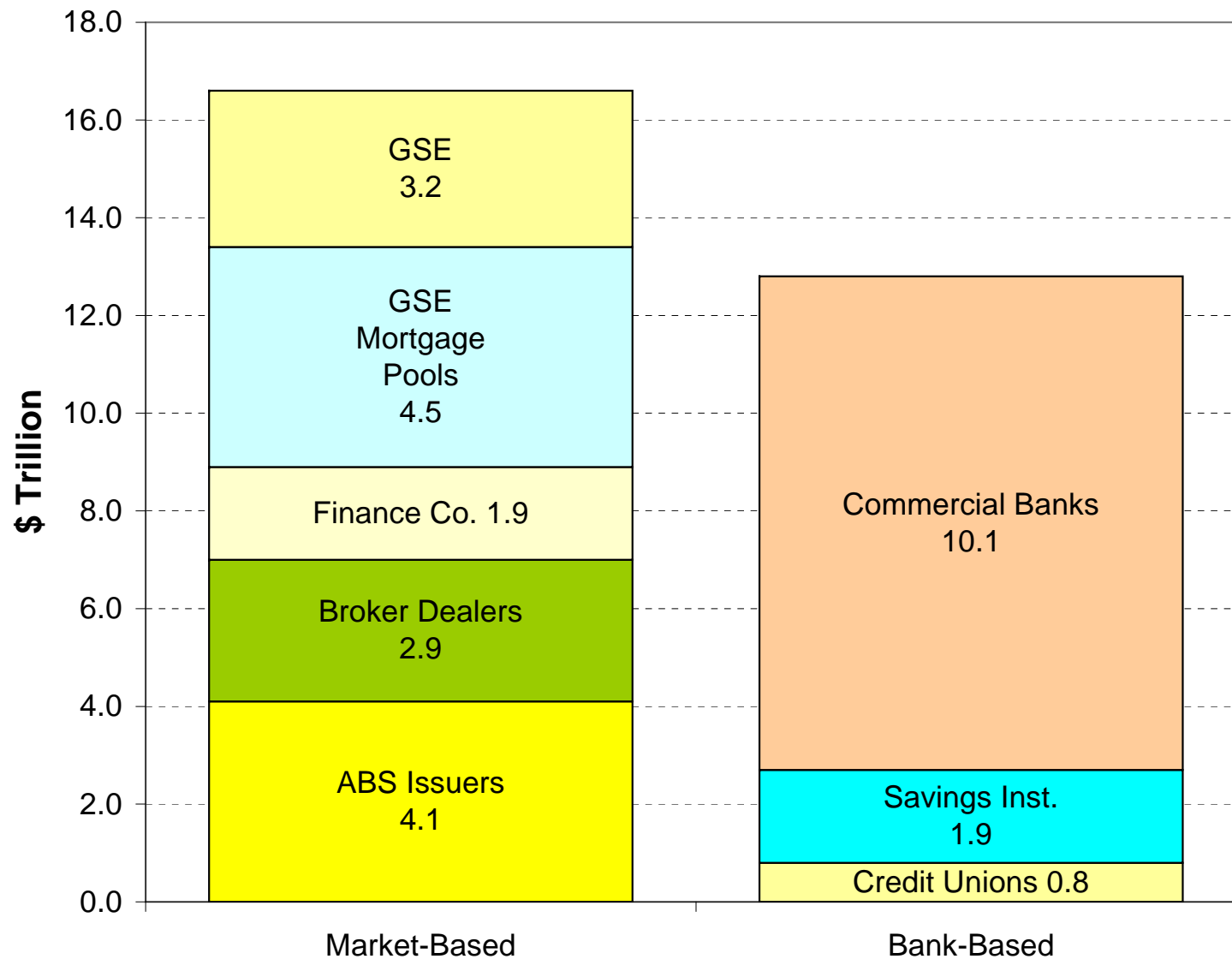

Holding of US Home Mortgages by Type of Financial Institution

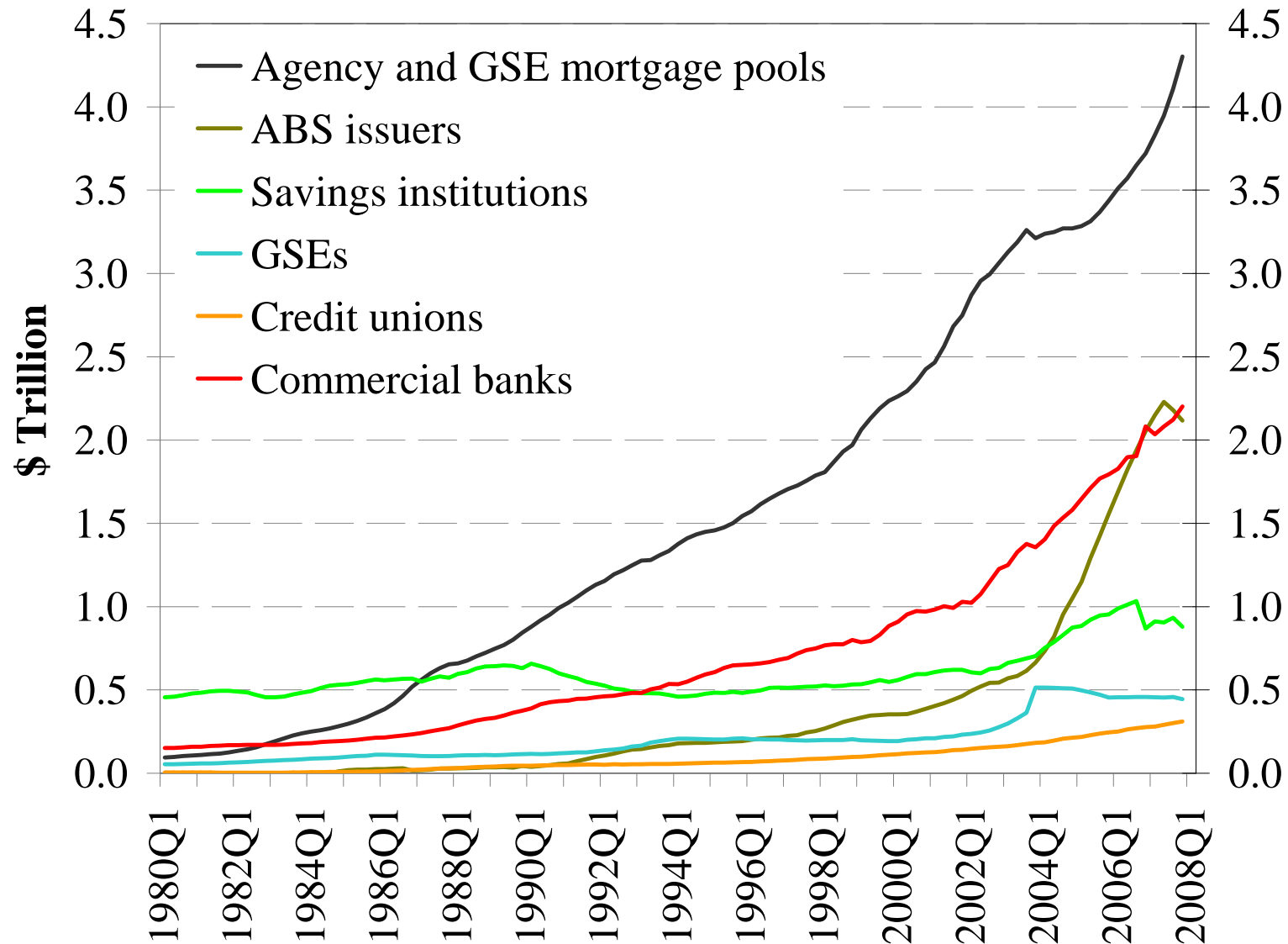

Market-Based and Bank-Based Holding of Home Mortgages

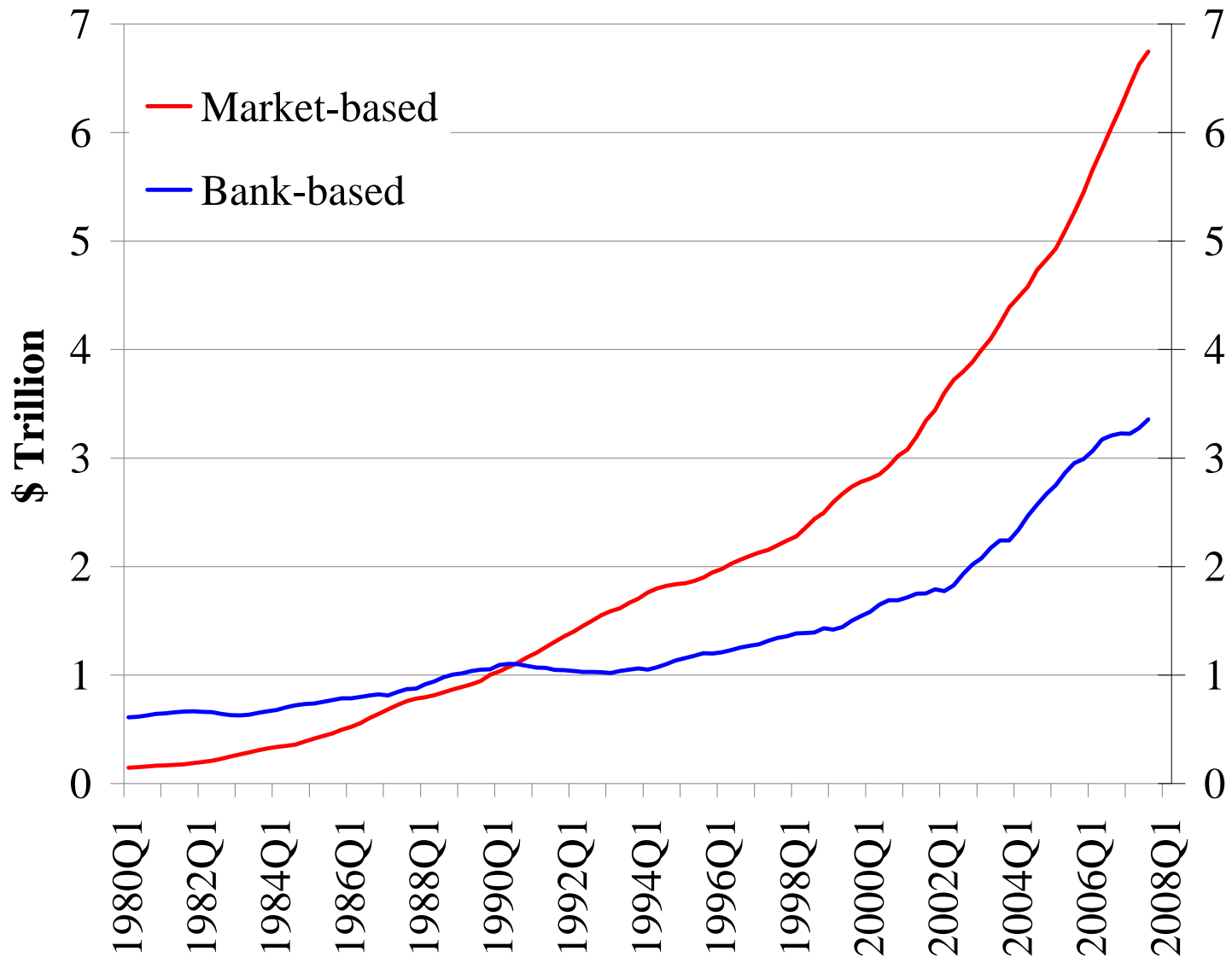

Short Intermediation Chain



Long Intermediation Chain

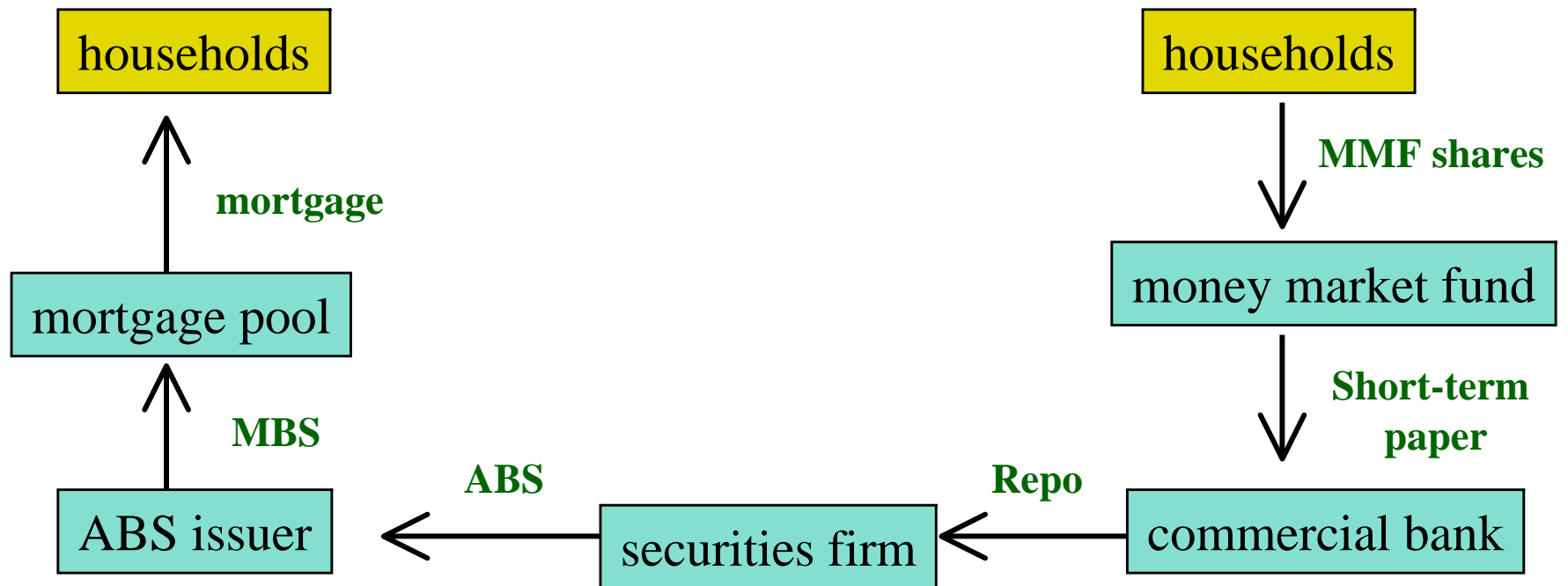

What Are the Advantages of the Long Intermediation Chain?

- “Securitization enables dispersion of credit risk”
- “Long chains promote more efficient maturity transformation”
 - “Households want short, liquid claims”
 - “Shadow banking system gives them what they want”

But Evidence in this Crisis Points the Other Way

- Securitization has *concentrated risks* in leveraged sector
- Biggest growth in short-term debt was *between* financial intermediaries
- Financial intermediaries have become more *intertwined*
 - “CoVaR” Adrian and Brunnermeier (2009)

Exposure to Subprime

	Total reported sub-prime exposure (US\$bn)	Percent of reported exposure
Investment Banks	75	5%
Commercial Banks	418	31%
GSEs	112	8%
Hedge Funds	291	21%
Insurance Companies	319	23%
Finance Companies	95	7%
Mutual and Pension Funds	57	4%
Leveraged Sector	896	66%
Unleveraged Sector	472	34%
Total	1,368	100%

Source: Greenlaw, Hatzius, Kashyap and Shin (2008)

Overnight repos, Financial CP and M2 (weekly, July 6 1994 as base date)

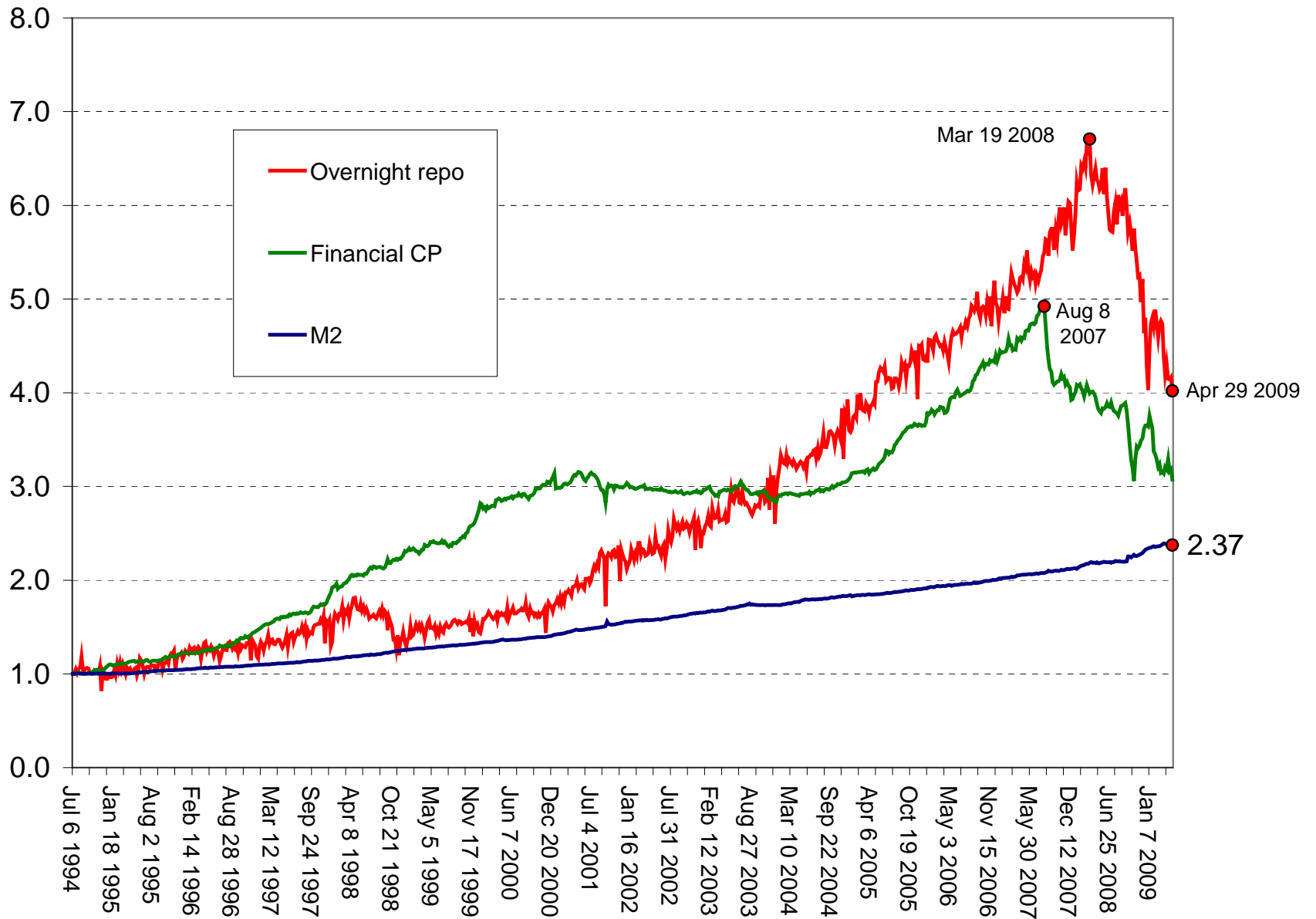

Repos and Financial CP as Fraction of M2 (weekly)

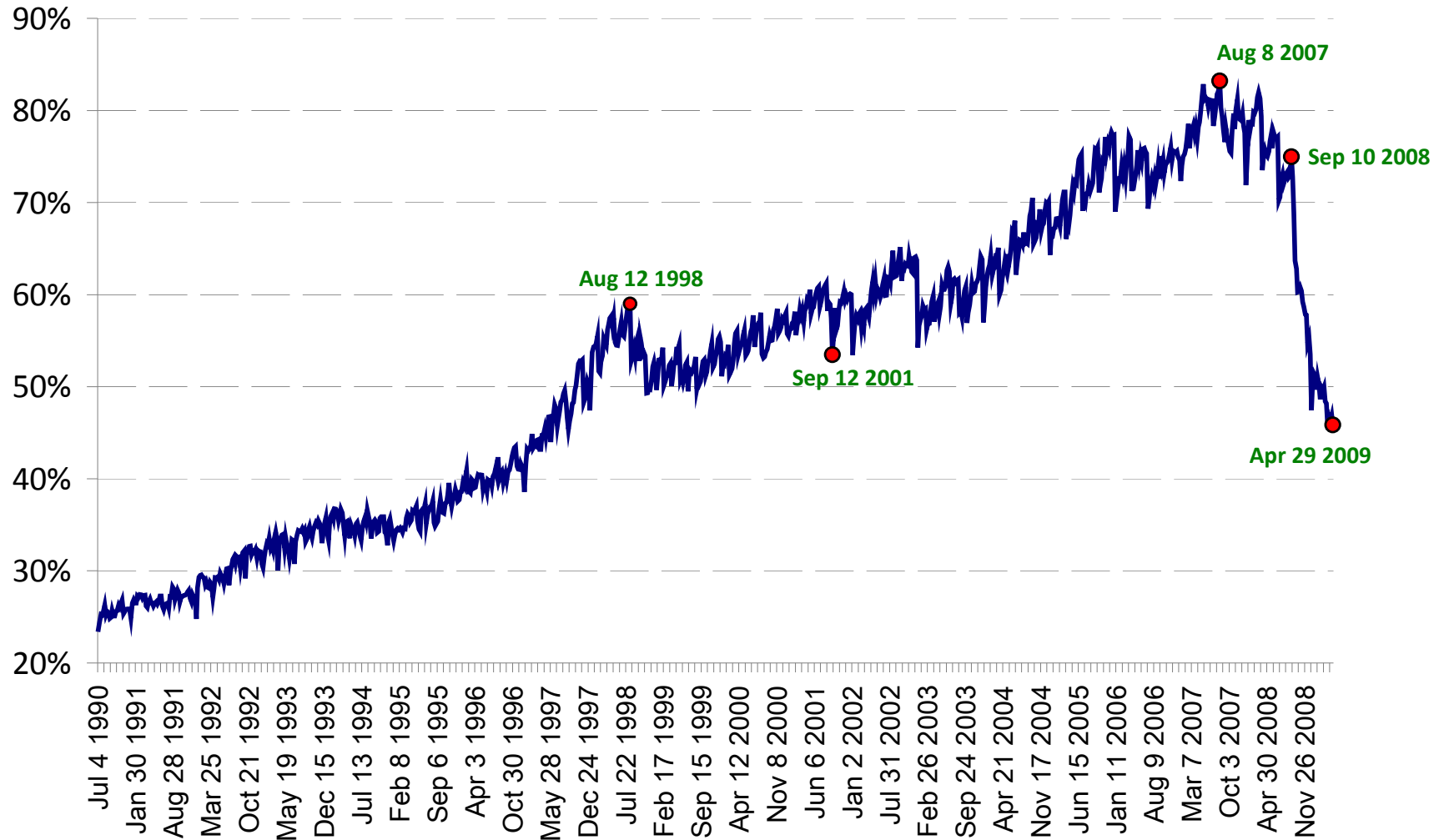

Source: Adrian and Shin (2009)

US Institutions' CoVaR

IMF Co-Risk Measures (March 2008)

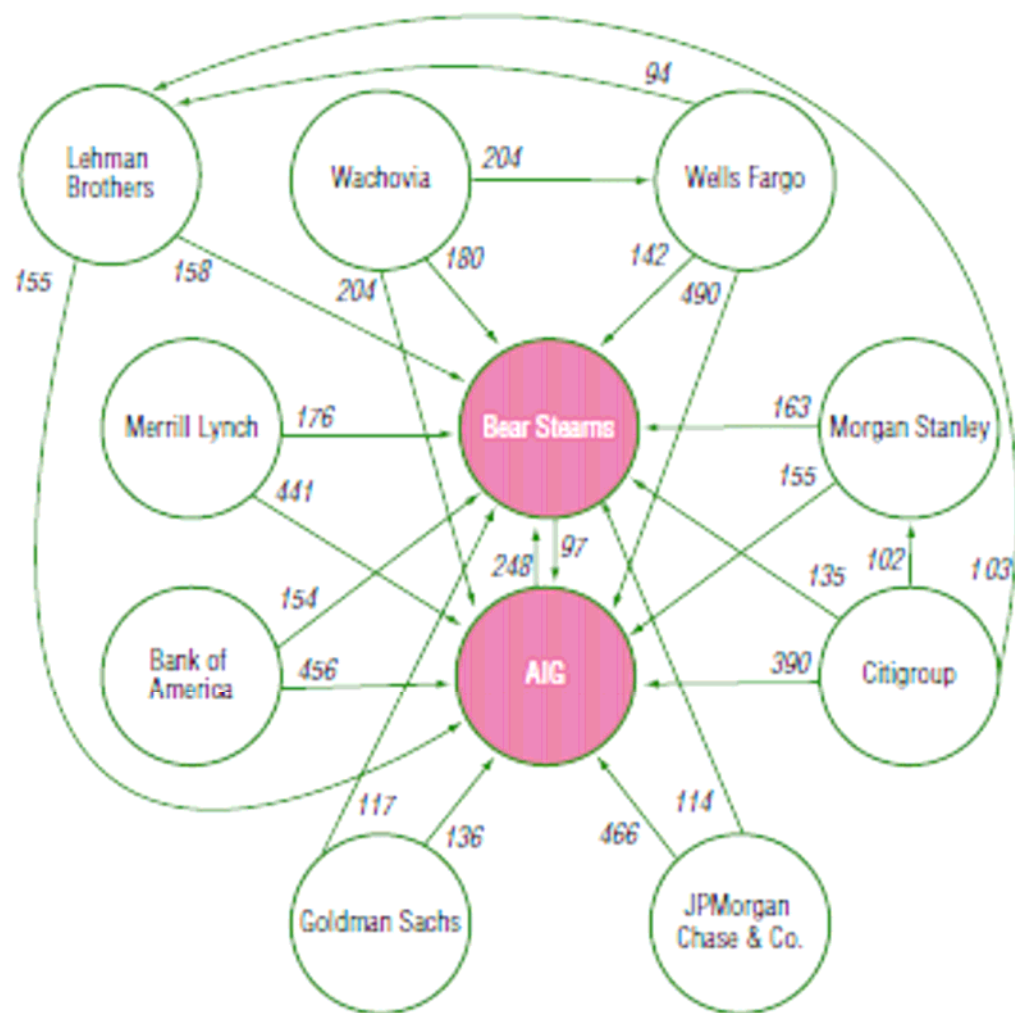

Source: IMF GFSR (April 2009)

Multi-layered Financial System

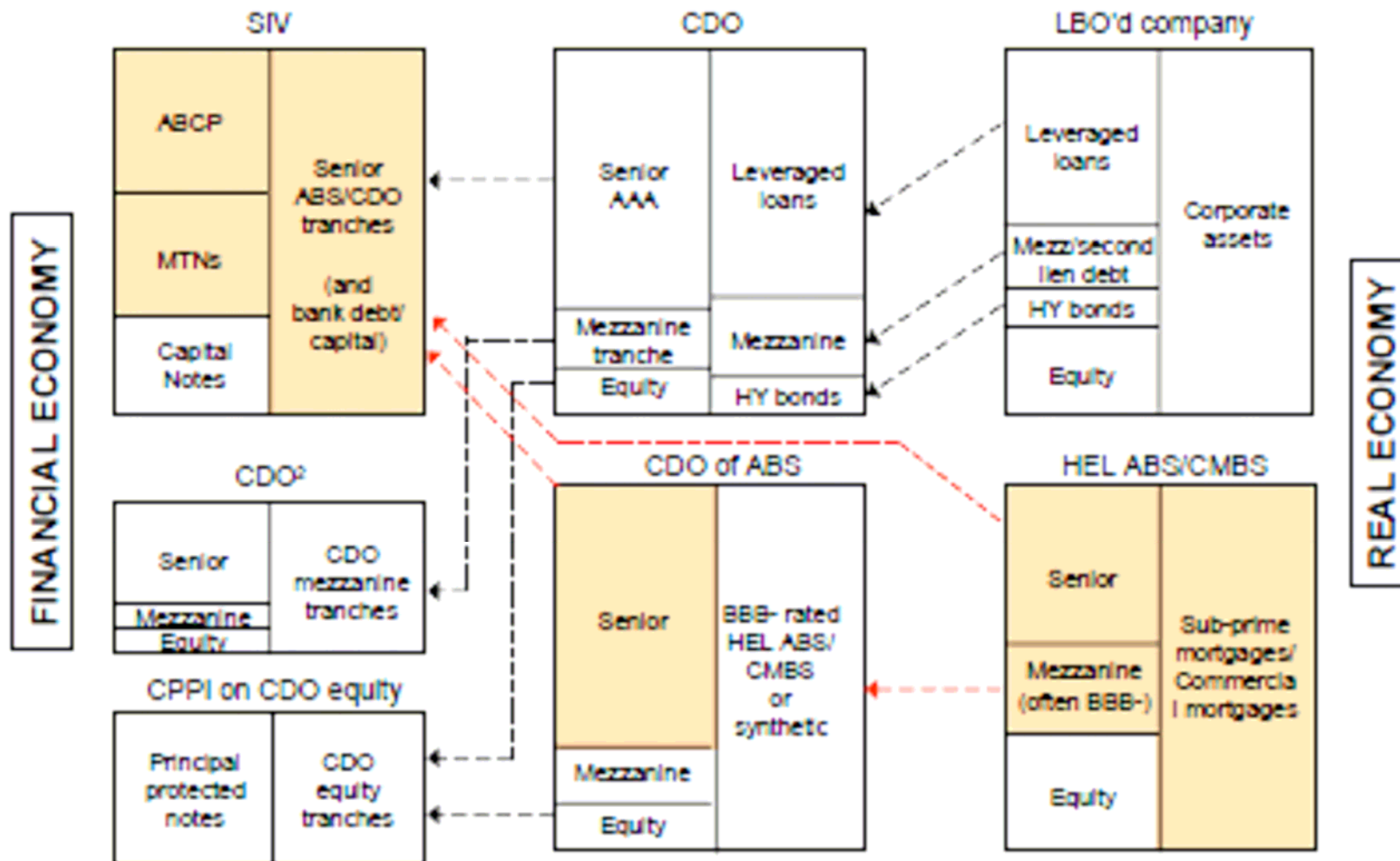

Source: Haldane (2009)

Global Interconnectedness

Chart 2: Global Financial Network: 1995

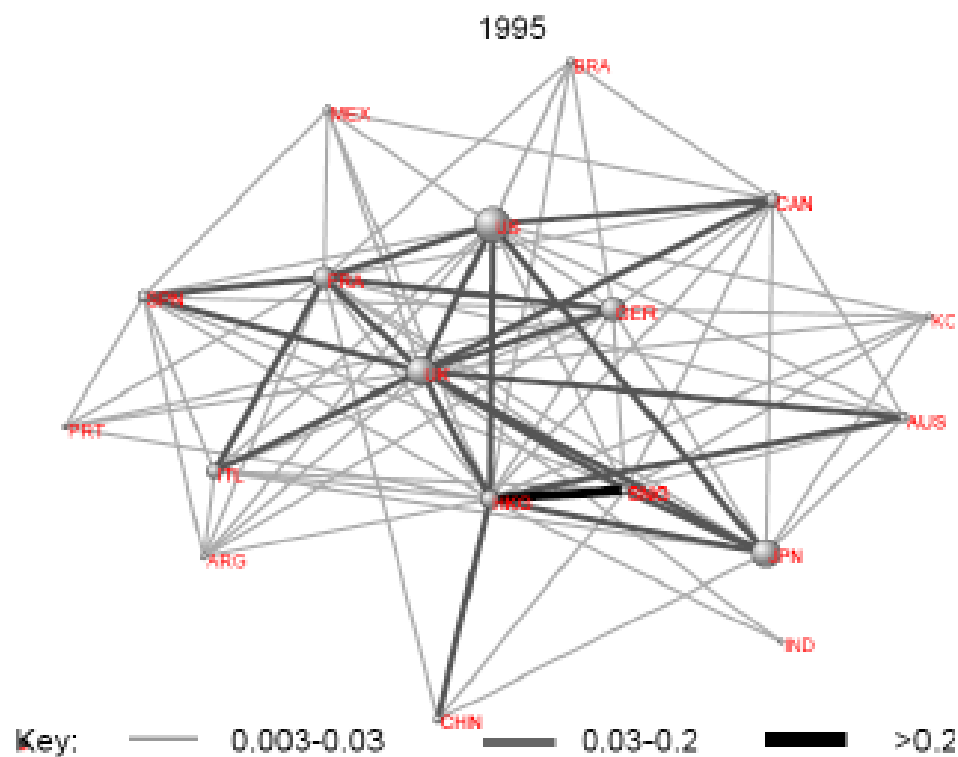
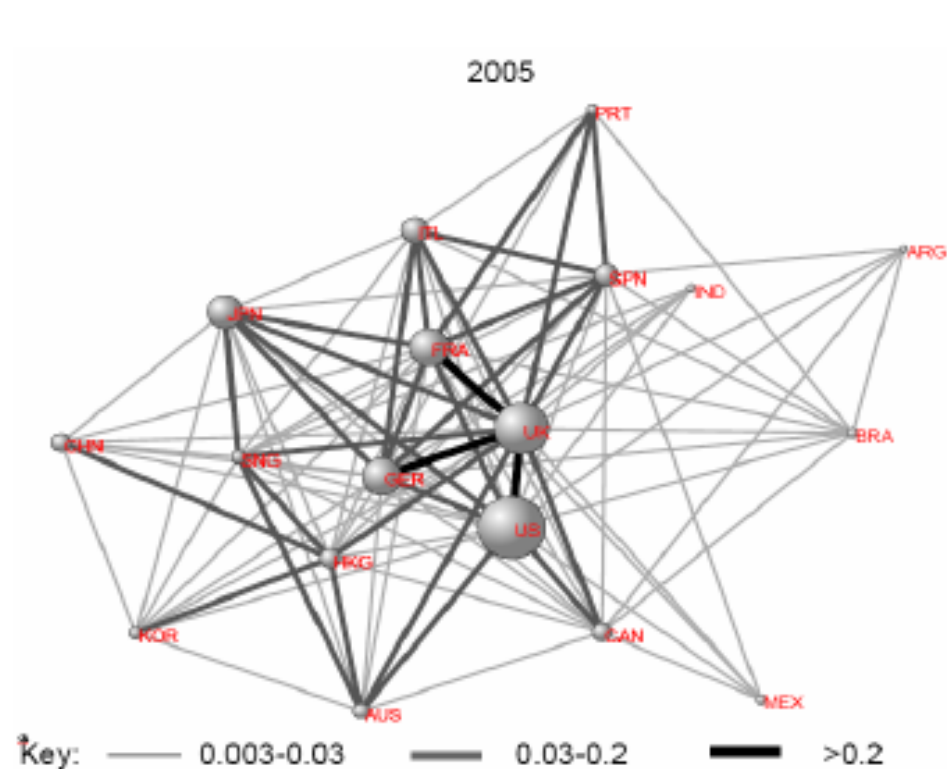

Chart 3: Global Financial Network: 2005



Source: Haldane (2009)

Relative Size of Intermediary Sector

Total Assets of Four Sectors [March 1954 = 1]

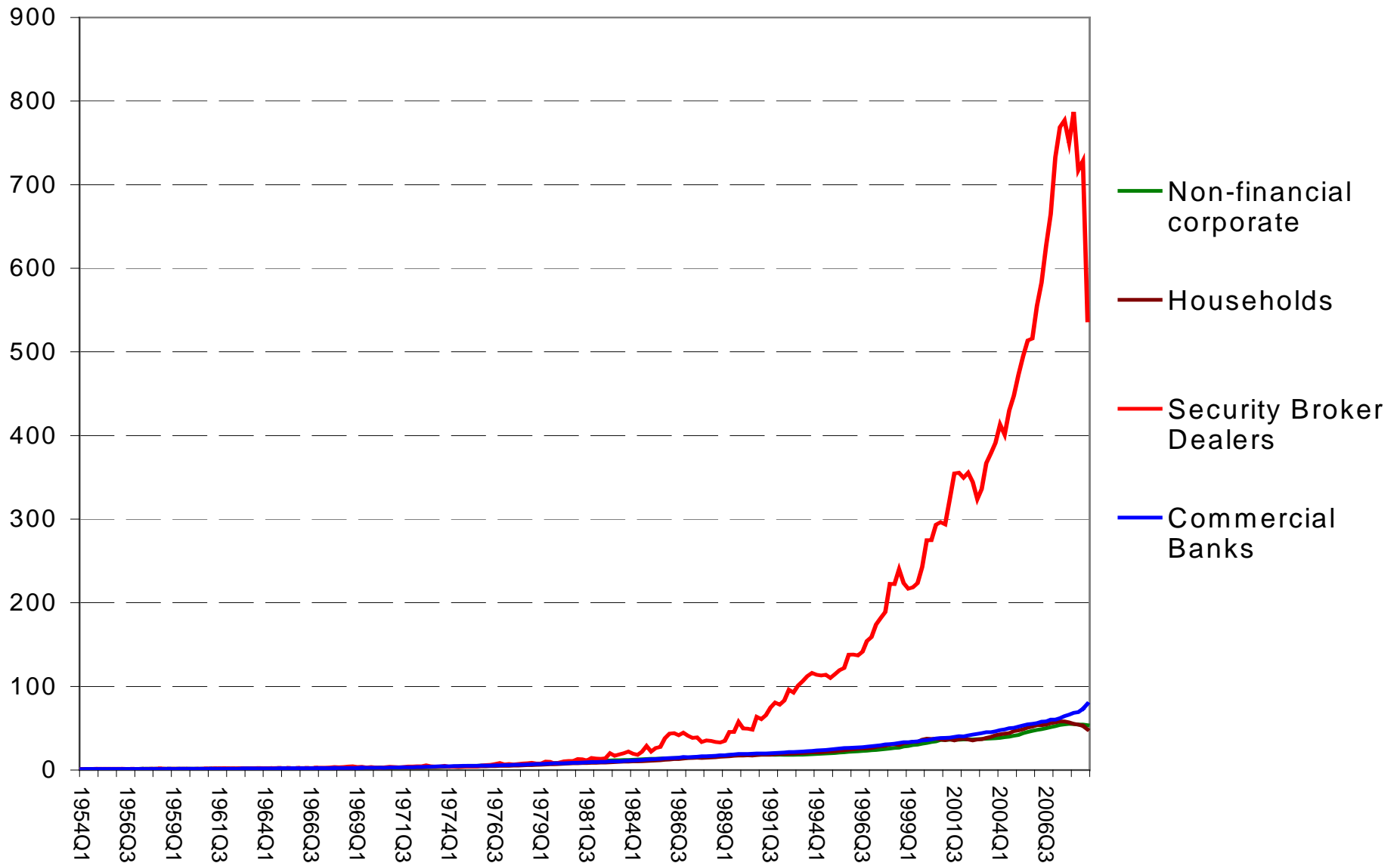

(Source: Federal Reserve, Flow of Funds)

Total Assets (Log Scale) [March 1954 = 1]

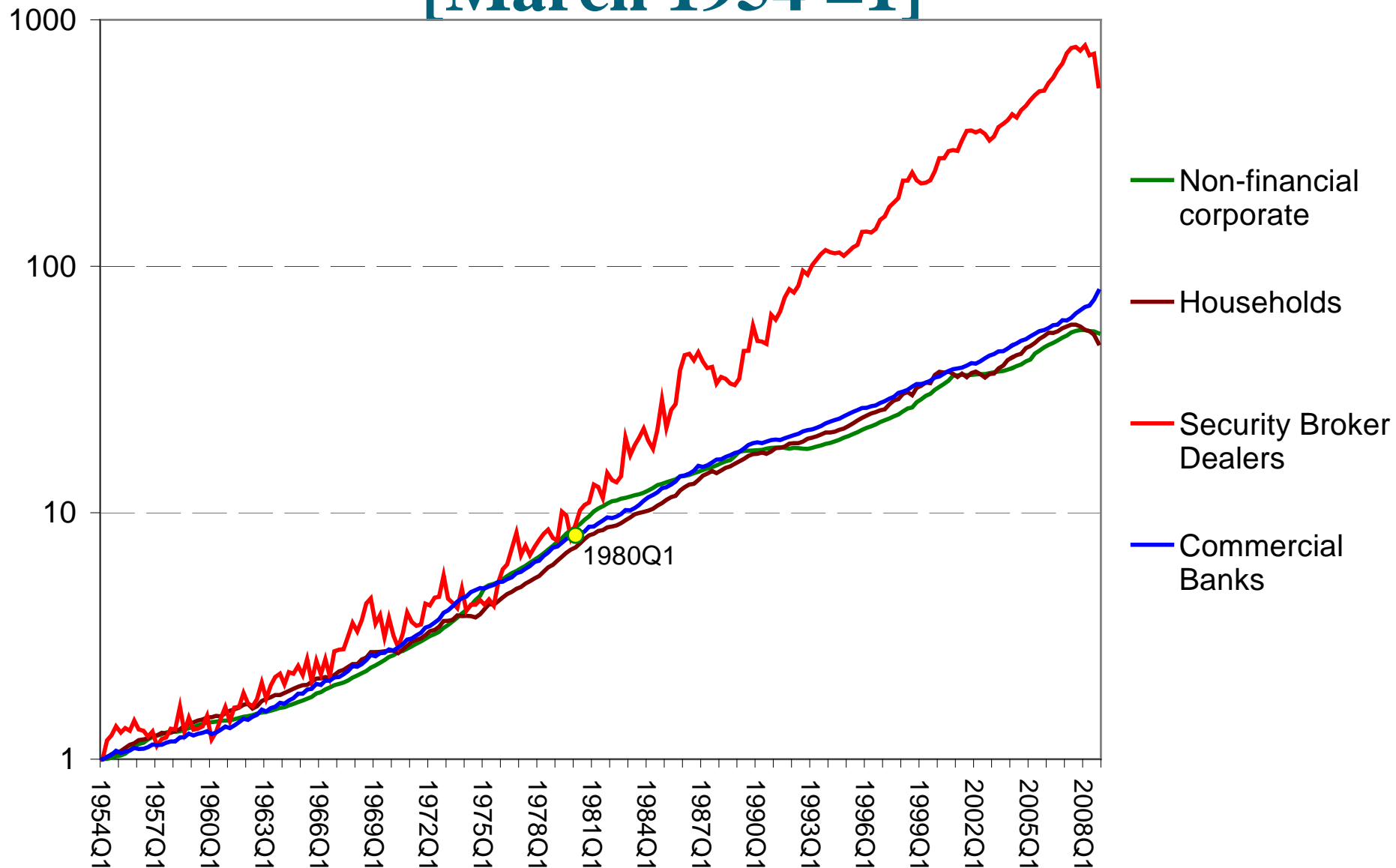

(Source: Federal Reserve, Flow of Funds)

Procyclical Leverage of Five US Investment Banks

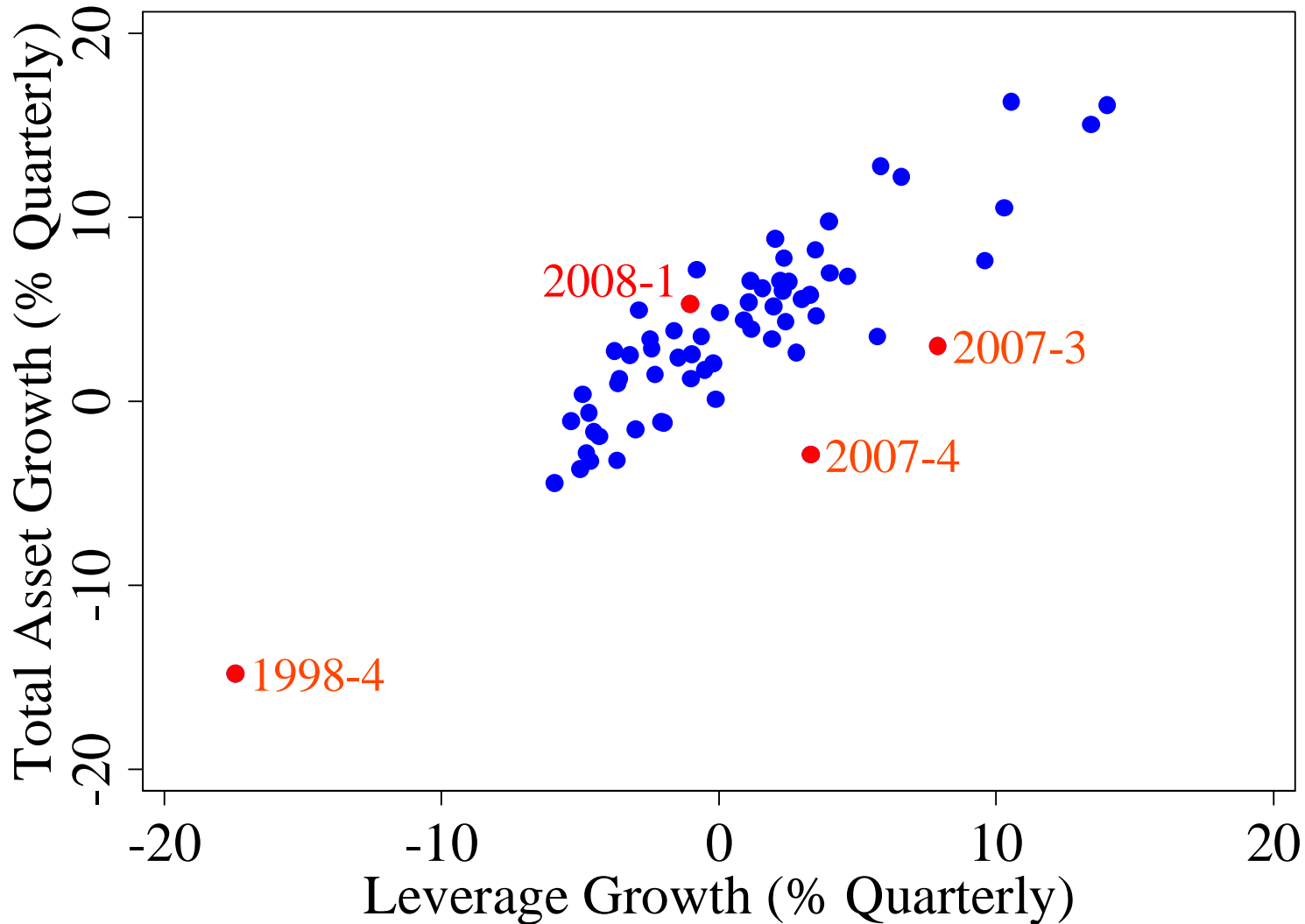

Source: Adrian and Shin (2007)

US Primary Dealer Mean Leverage

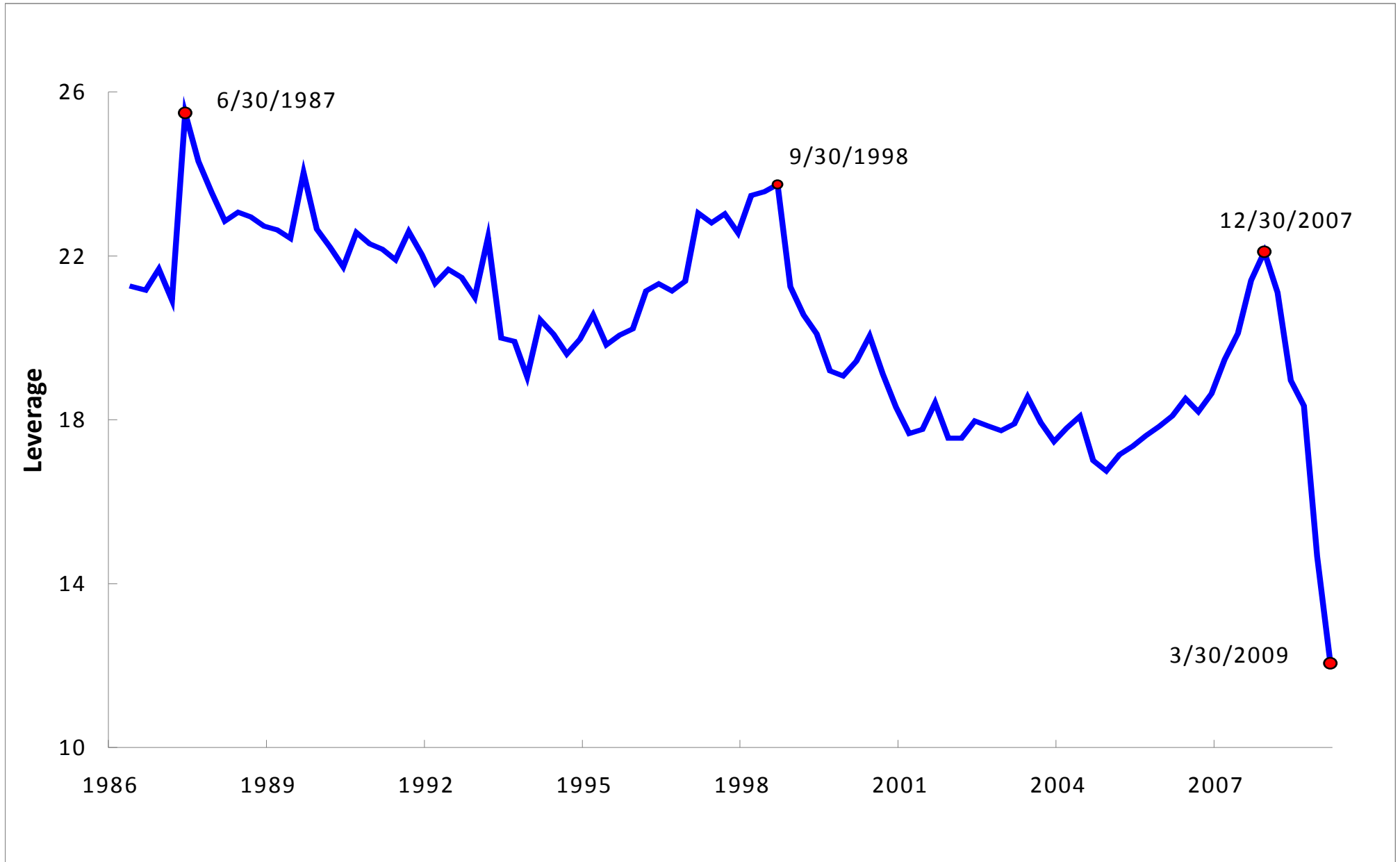

All Primary Dealer Mean Leverage

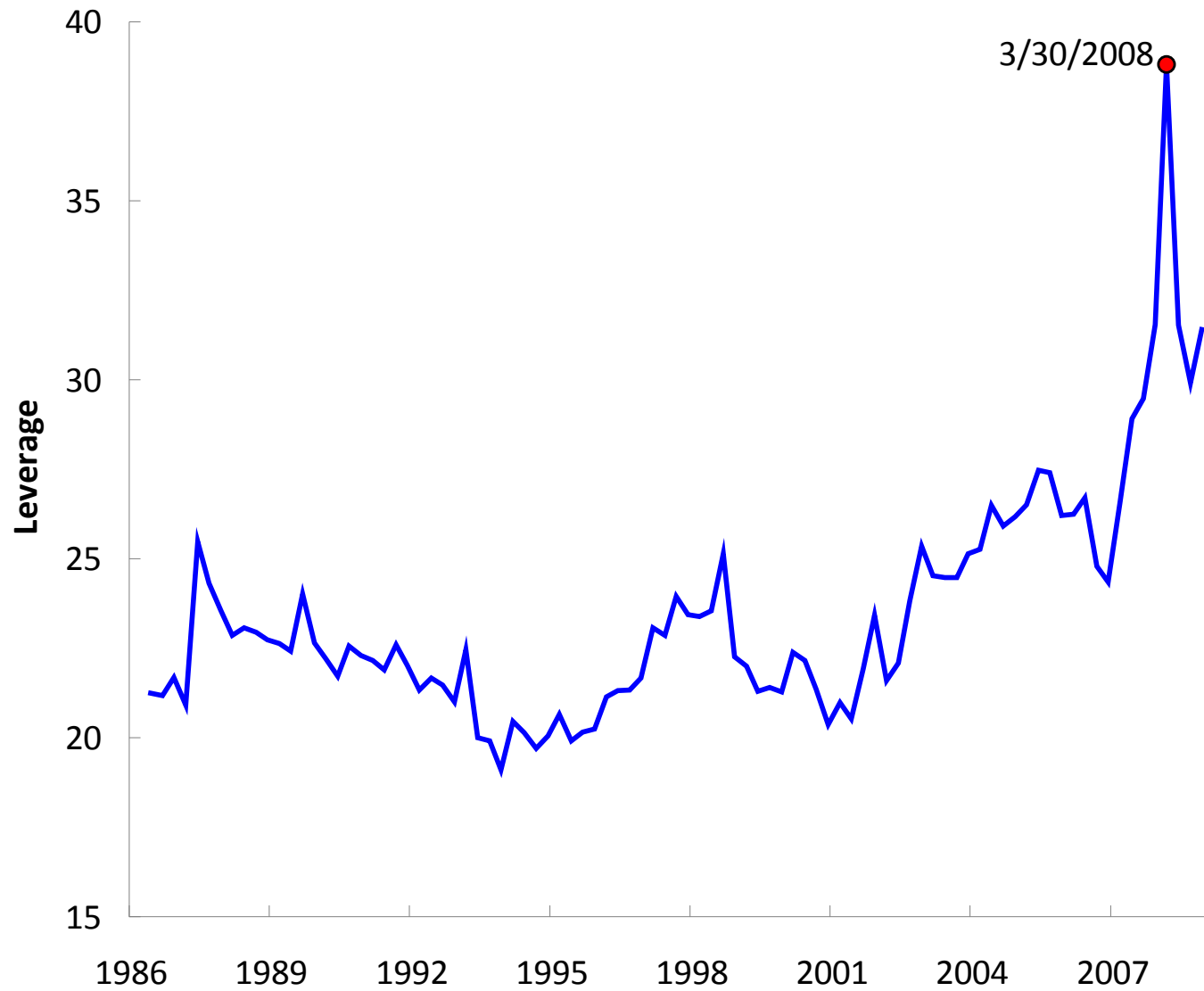

New Issuance of Asset Backed Securities in Previous Three Months

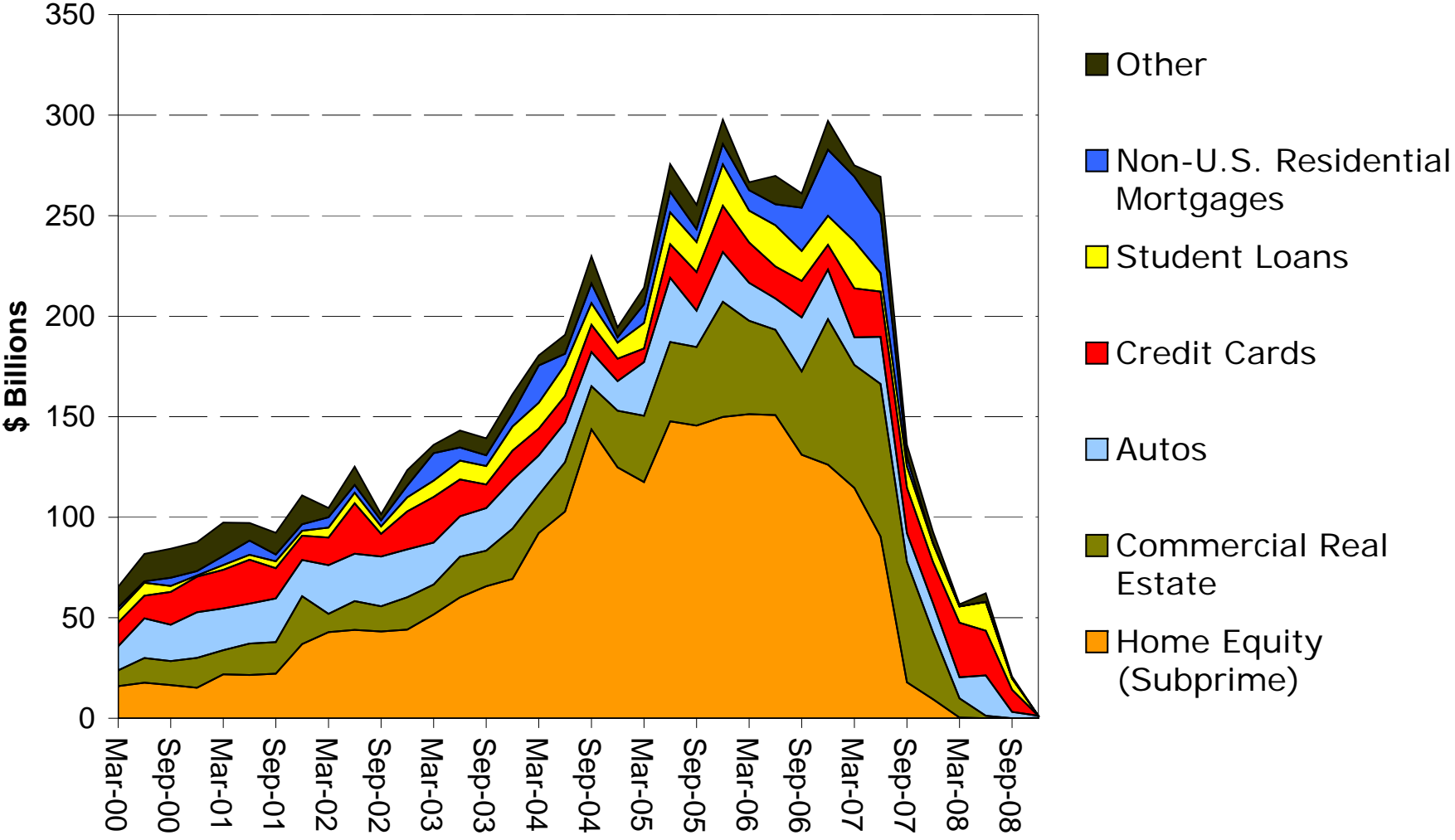

Source: JP Morgan

Biggest Damage is Done in Contractions

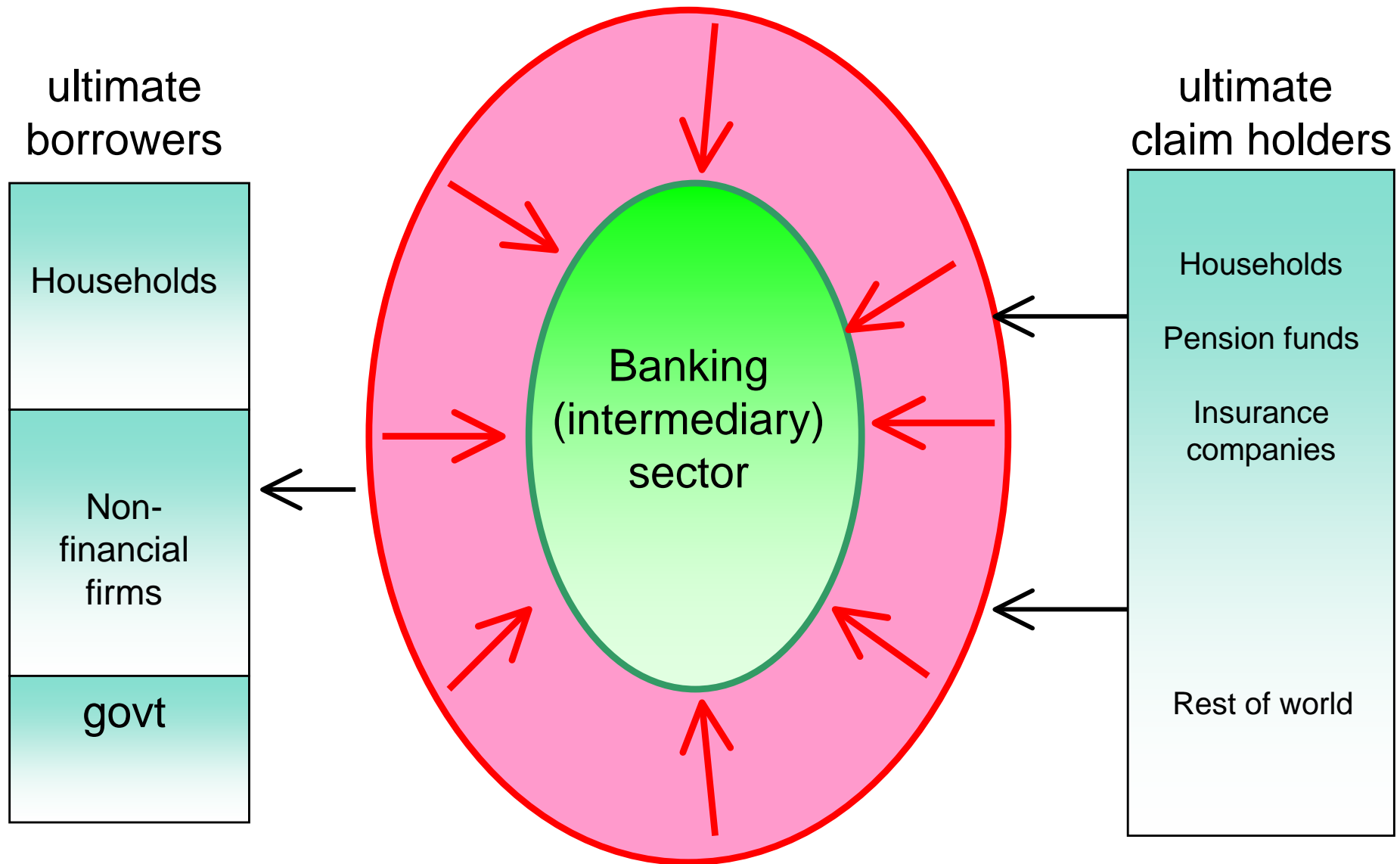

But Seeds of Crises Are Sown in Expansions

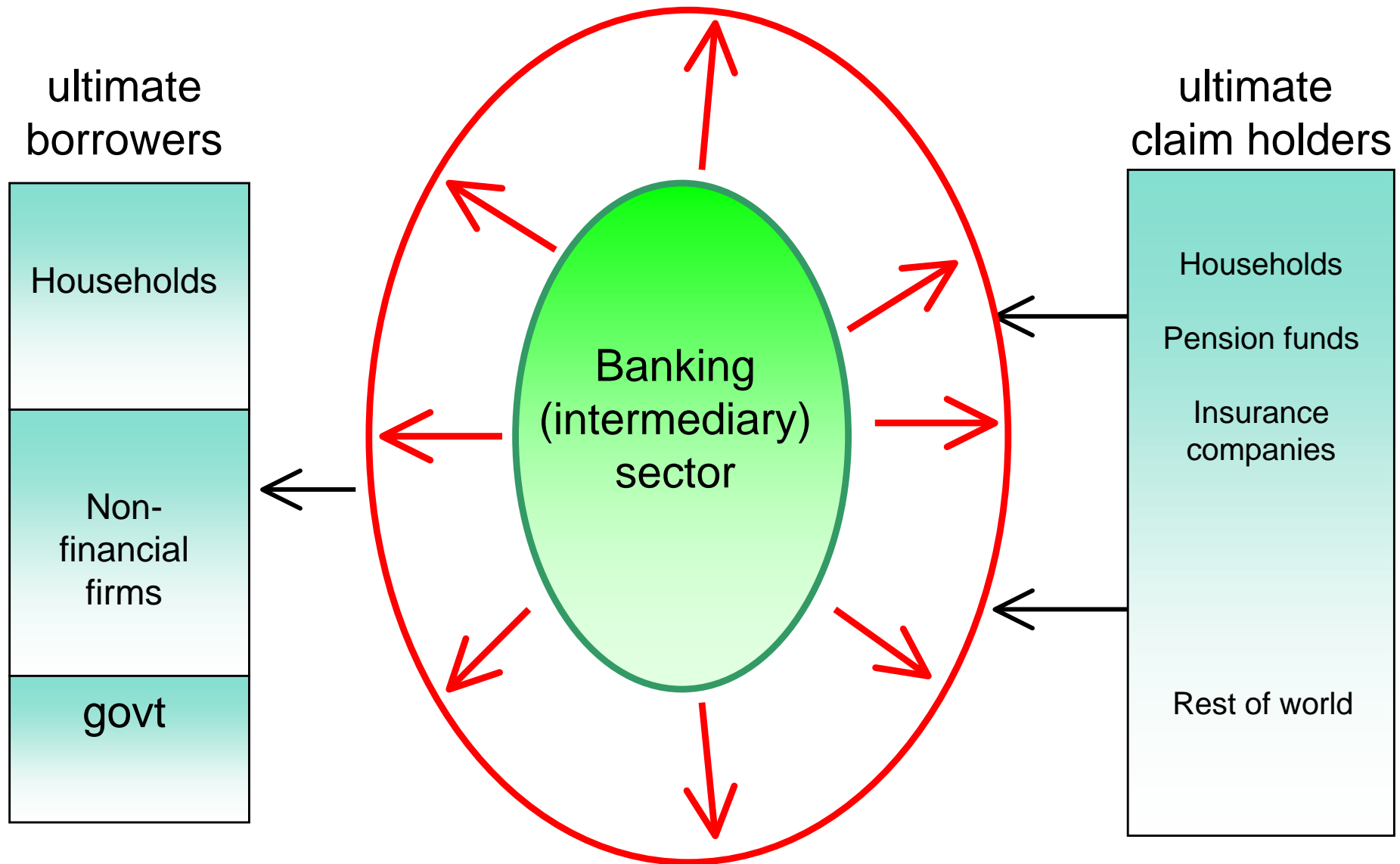

How To Moderate Balance Sheet Boom/Bust Cycles?

Individual Bank Balance Sheet

Assets

Liabilities

Loans to firms, households	Liabilities to non-banks (e.g. deposits)
Claims on other banks	Liabilities to other banks
	Equity

Individual bank

Balance Sheet for Banking Sector

Assets

Liabilities

Total lending to ultimate borrowers (firms, households govt)	<table border="1"><tr><td data-bbox="1031 618 1751 813">Total debt liabilities to non-banks</td></tr><tr><td data-bbox="1031 813 1751 1052">Total equity</td></tr></table>	Total debt liabilities to non-banks	Total equity
Total debt liabilities to non-banks			
Total equity			

Banking sector

**Slow moving:
increases in line
with household wealth**

Aggregate Balance Sheet Identity

$$\sum_{i=1}^n y_i = \sum_{i=1}^n e_i z_i (\lambda_i - 1) + \sum_{i=1}^n e_i$$

Total lending to
ultimate borrowers

Total debt liabilities
To non-banks

Total equity of
intermediaries

Booms

- Higher leverage of financial intermediaries
- Larger balance sheets of intermediaries
- Greater intertwining of intermediaries
 - Longer chains
 - Maturity mismatch to sustain longer chains

Architectural Analogy

- Adding extra capacity (more rooms) to a house when constrained by limited footprint
 - The only way is to build up (like a Manhattan skyscraper)
 - Except that Manhattan skyscraper is planned ahead, as a coherent whole
 - Better analogy is adding extra floors to a building without anticipating future floors on top

Sutyagin House in Archangel



Busts

- Deleveraging
- Shrinking balance sheets
- Unraveling of interbank lending
 - Runs
 - Retrenchment

Northern Rock



Bear Stearns Liquidity Pool (US\$ billions)
(Source: SEC)

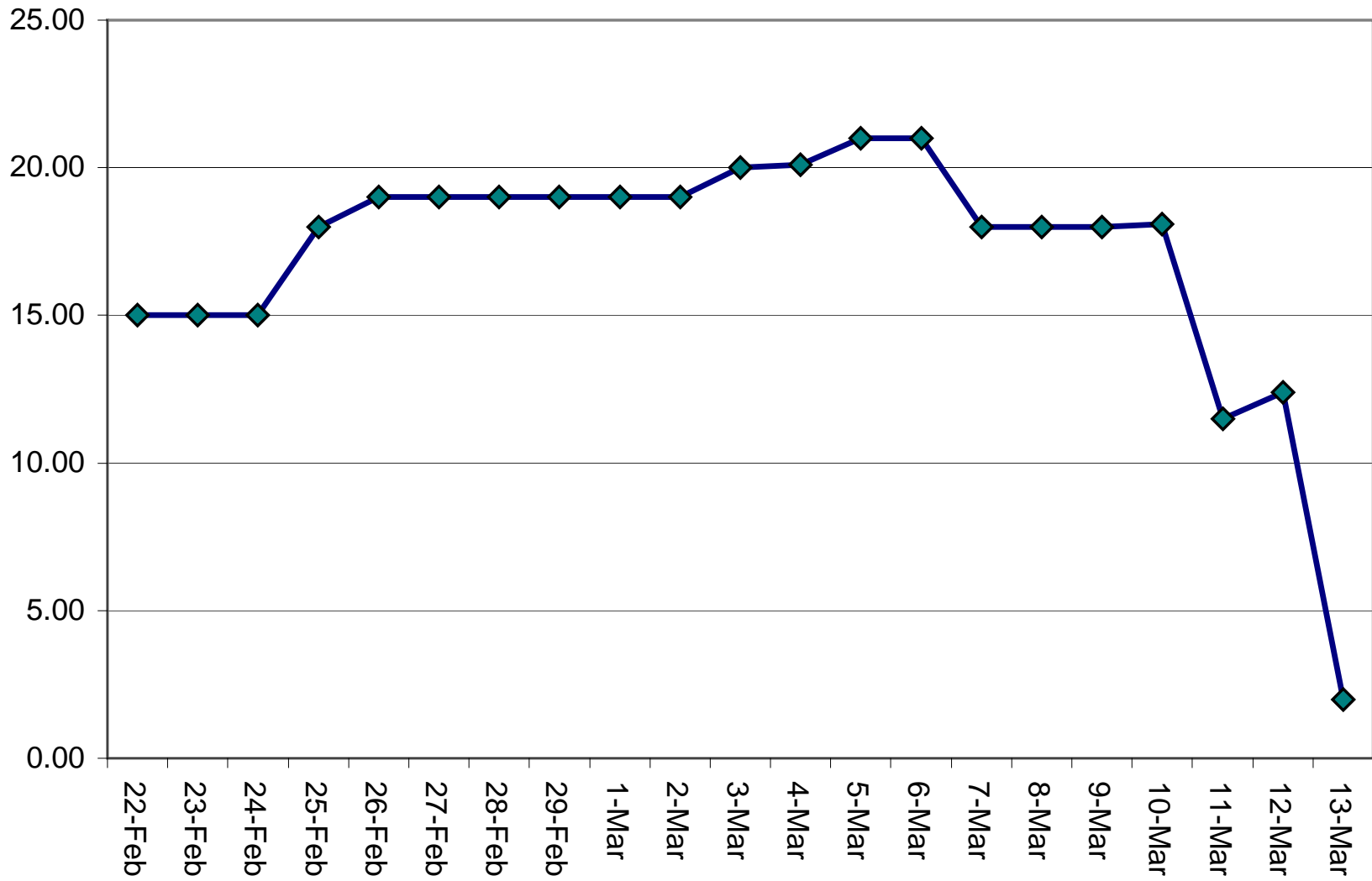

What Prescriptions for Better Functioning Intermediary Sector?

Approach 1: Moderate Fluctuations in Leverage through Countercyclical Capital Regulation

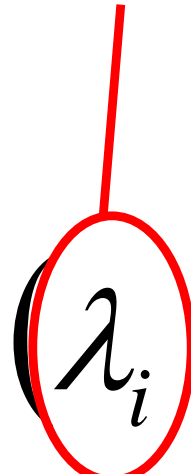
$$\sum_{i=1}^n y_i = \sum_{i=1}^n e_i z_i (\lambda_i - 1) + \sum_{i=1}^n e_i$$

- Leverage cap (e.g. Switzerland)
- Countercyclical capital targets (Geneva Report)

Approach 2: Moderate Fluctuations in Equity through Forward-looking Provisioning

$$\sum_{i=1}^n y_i = \sum_{i=1}^n e_i z_i (\lambda_i - 1) + \sum_{i=1}^n e_i$$

- Spanish Statistical Provisioning
- Pigovian Tax (Geneva Report)

Approach 3: Shortening Intermediation Chains through Development of New Instruments

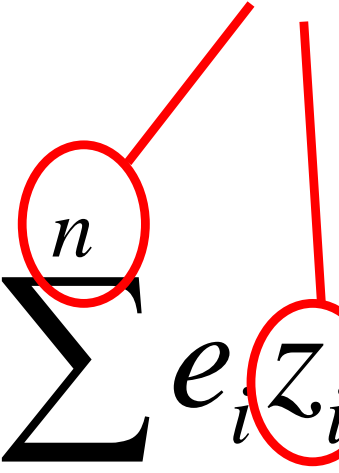
$$\sum_{i=1}^n y_i = \sum_{i=1}^n e_i z_i (\lambda_i - 1) + \sum_{i=1}^n e_i$$

Covered bonds

- Danish mortgage bonds
- German pfandbrief bonds

Long Intermediation Chain

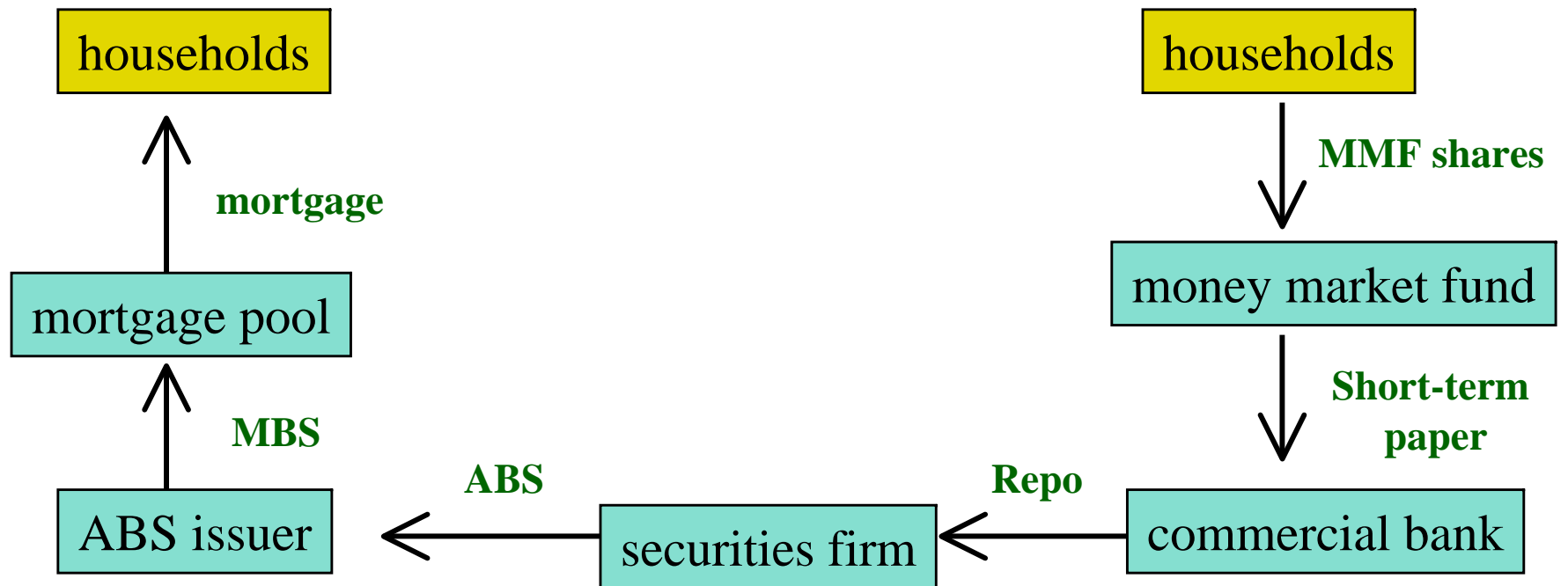

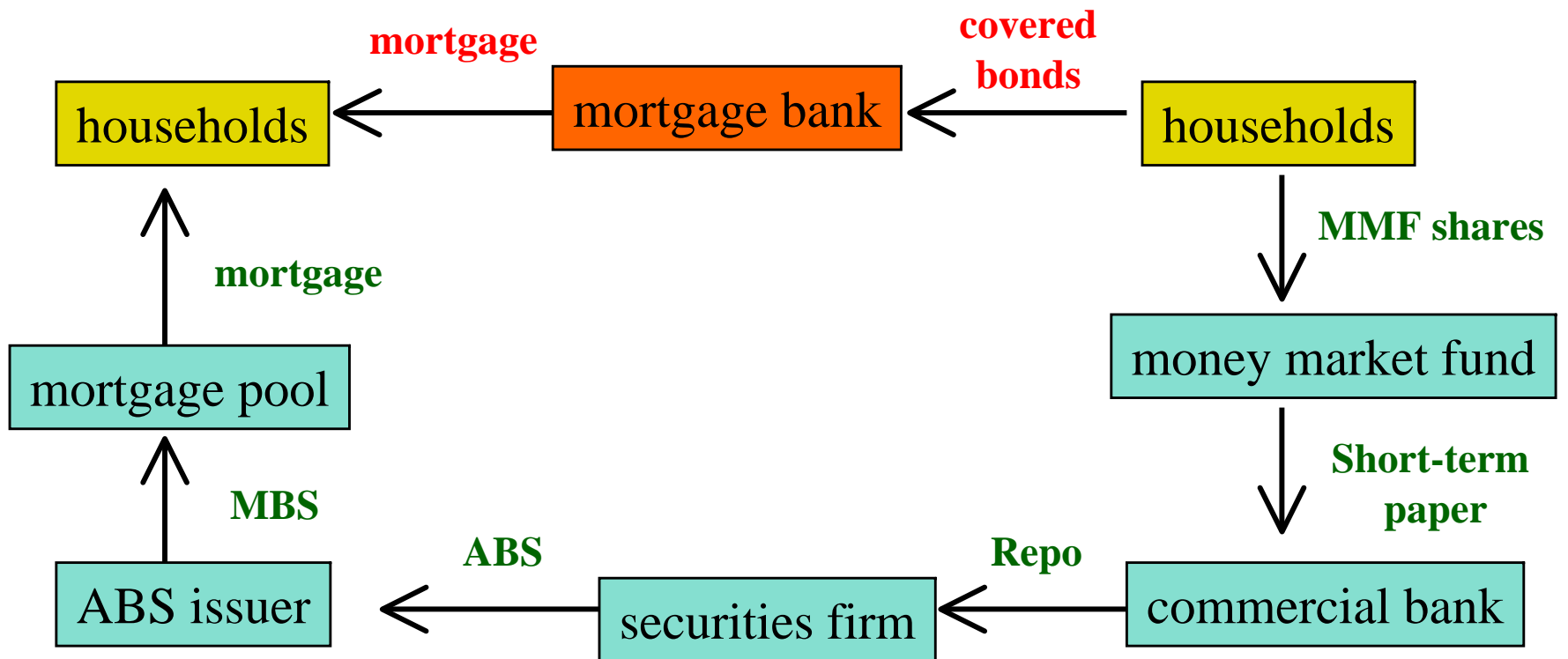

Investors in Covered Bonds

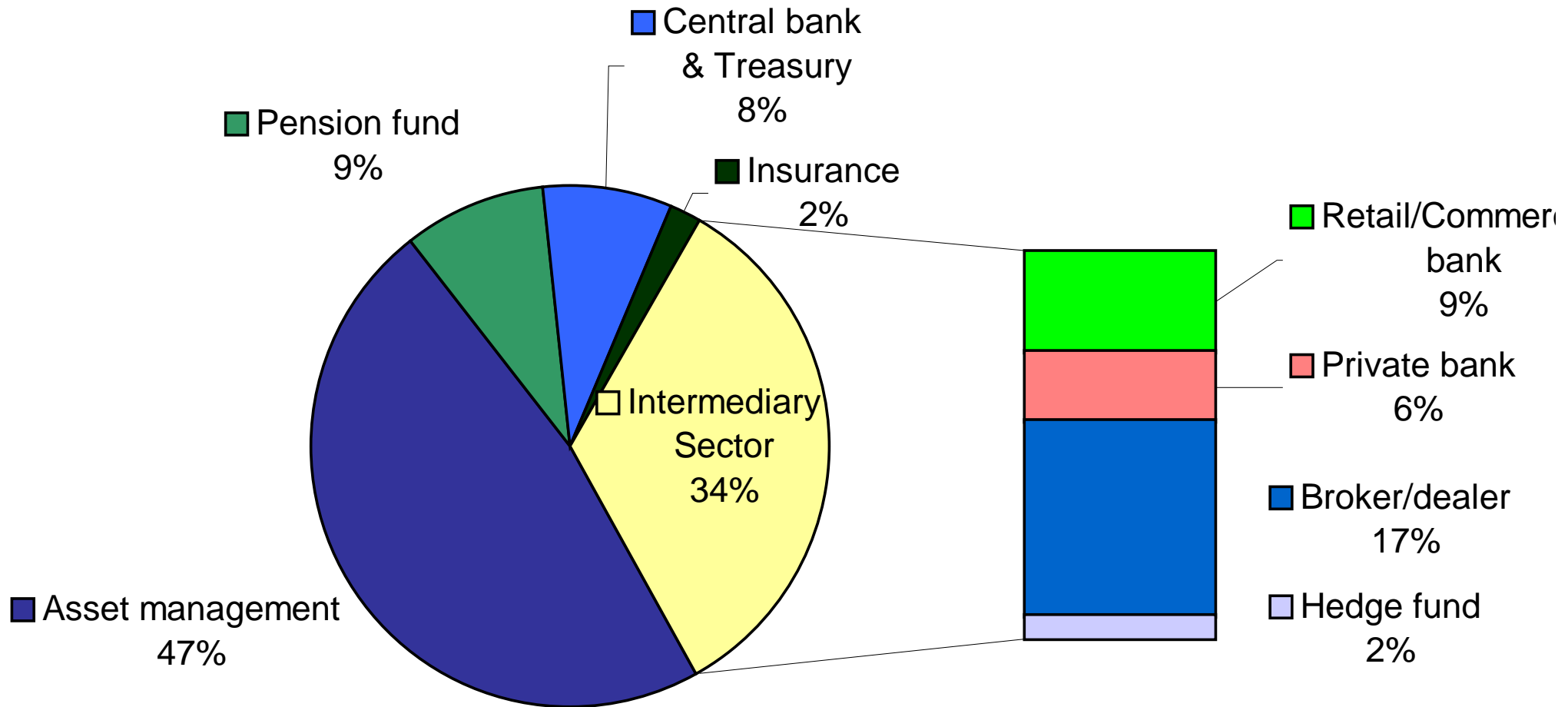

Source: SIFMA (2009)

Hurdles to be Overcome

- Seniority of depositors (and hence deposit insurance agency)
 - In the United States, FDIC policy is to restrict covered bonds to 4% or less of total liabilities
 - An alternative is to develop specialist “narrow” covered bond banks who do not take deposits and only issue covered bonds
 - Model provided by mortgage banks in Denmark

Some Features of Possible Future Financial System

- Smaller intermediary sector
 - Especially securities sector
- Shorter intermediation chains
 - Less profitable
 - Less maturity transformation
- With regulatory brakes
- Monetary policy?
- Accounting standards?